

8 7 6 5 4 3 2 1

D
C
B
A

D
C
B
A

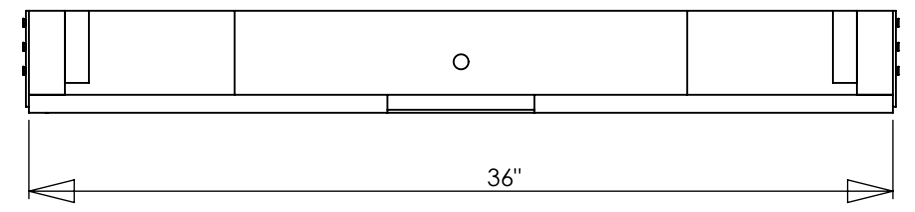
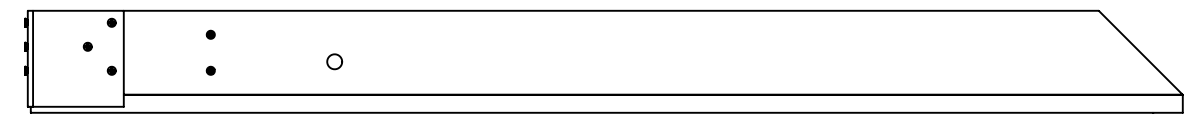
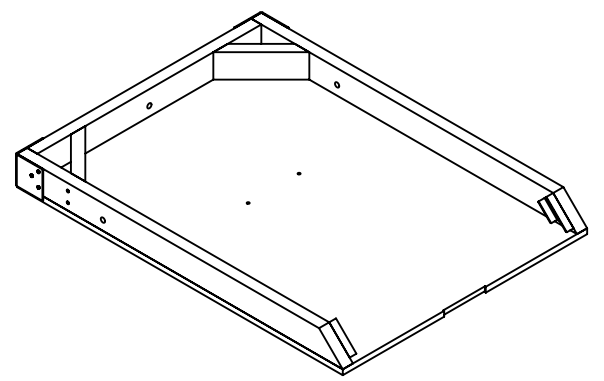
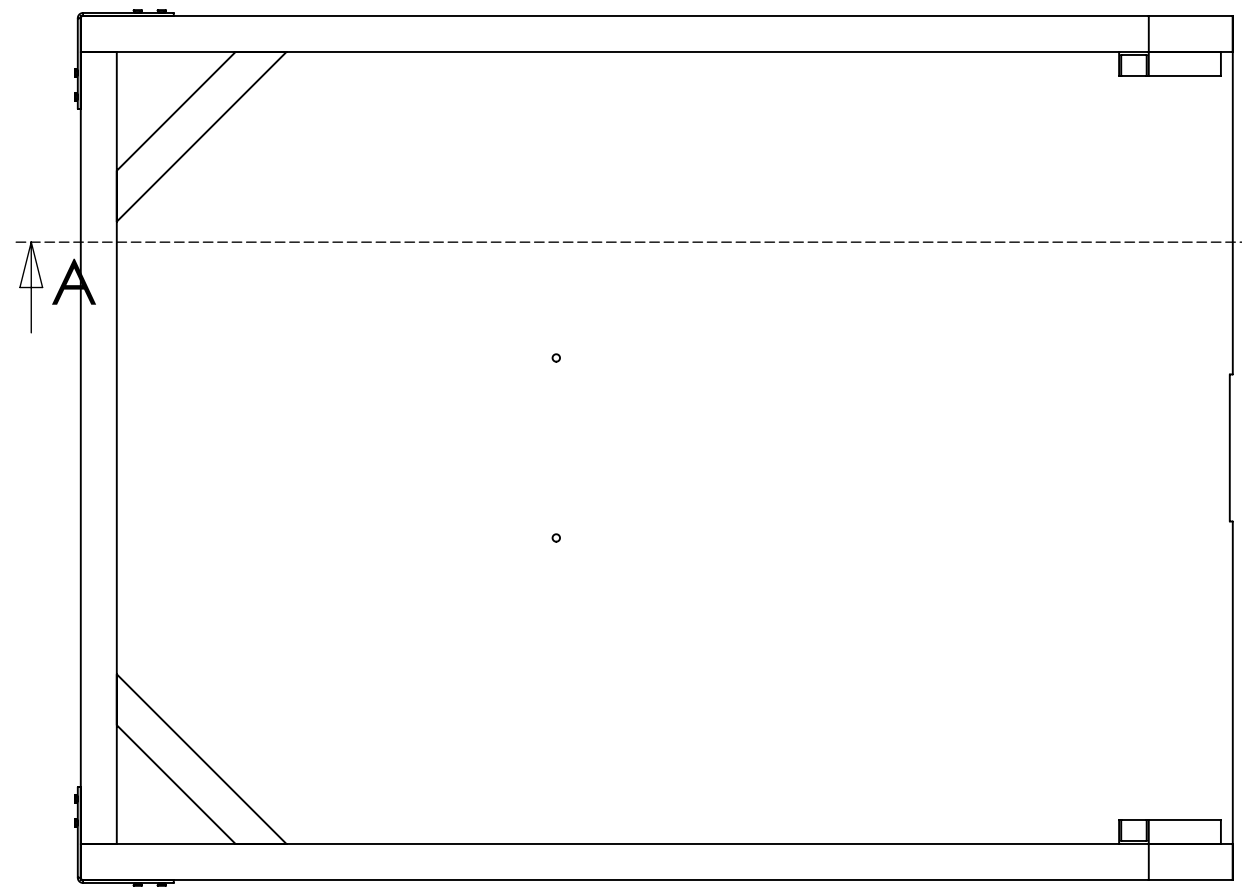

SECTION A-A

PROPRIETARY AND CONFIDENTIAL
 THE INFORMATION CONTAINED IN THIS DRAWING IS THE SOLE PROPERTY OF National Horseshoe Pitcher's Association. ANY REPRODUCTION IN PART OR AS A WHOLE WITHOUT THE WRITTEN PERMISSION OF National Horseshoe Pitcher's Association IS PROHIBITED.

		UNLESS OTHERWISE SPECIFIED:		NAME	DATE	NATIONAL HORSESHOE PITCHER'S ASSOCIATION
		DIMENSIONS ARE IN INCHES TOLERANCES: FRACTIONAL ± ANGULAR: MACH ± BEND ± TWO PLACE DECIMAL ± THREE PLACE DECIMAL ±		DRAWN	CAR	
		INTERPRET GEOMETRIC TOLERANCING PER:		CHECKED		TITLE:
		MATERIAL		ENG APPR.		BASE ASSEMBLY
		SEE PART LIST		MFG APPR.		
		FINISH		Q.A.		SIZE
NEXT ASSY	USED ON			COMMENTS:		DWG. NO.
APPLICATION		DO NOT SCALE DRAWING				B
						BA
						REV
						SCALE: 1:8
						WEIGHT:
						SHEET 1 OF 4

8 7 6 5 4 3 2 1

8 7 6 5 4 3 2 1

D
C
B
A

D
C
B
A

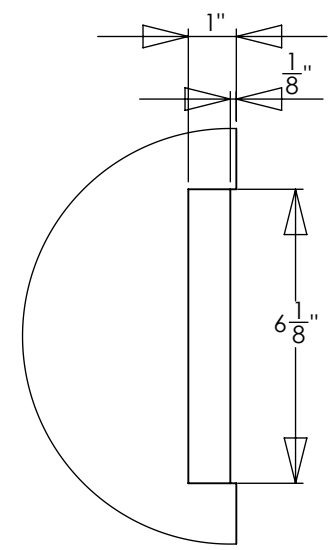
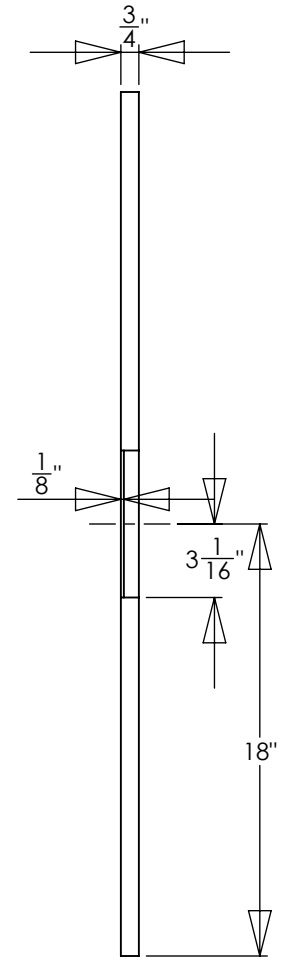
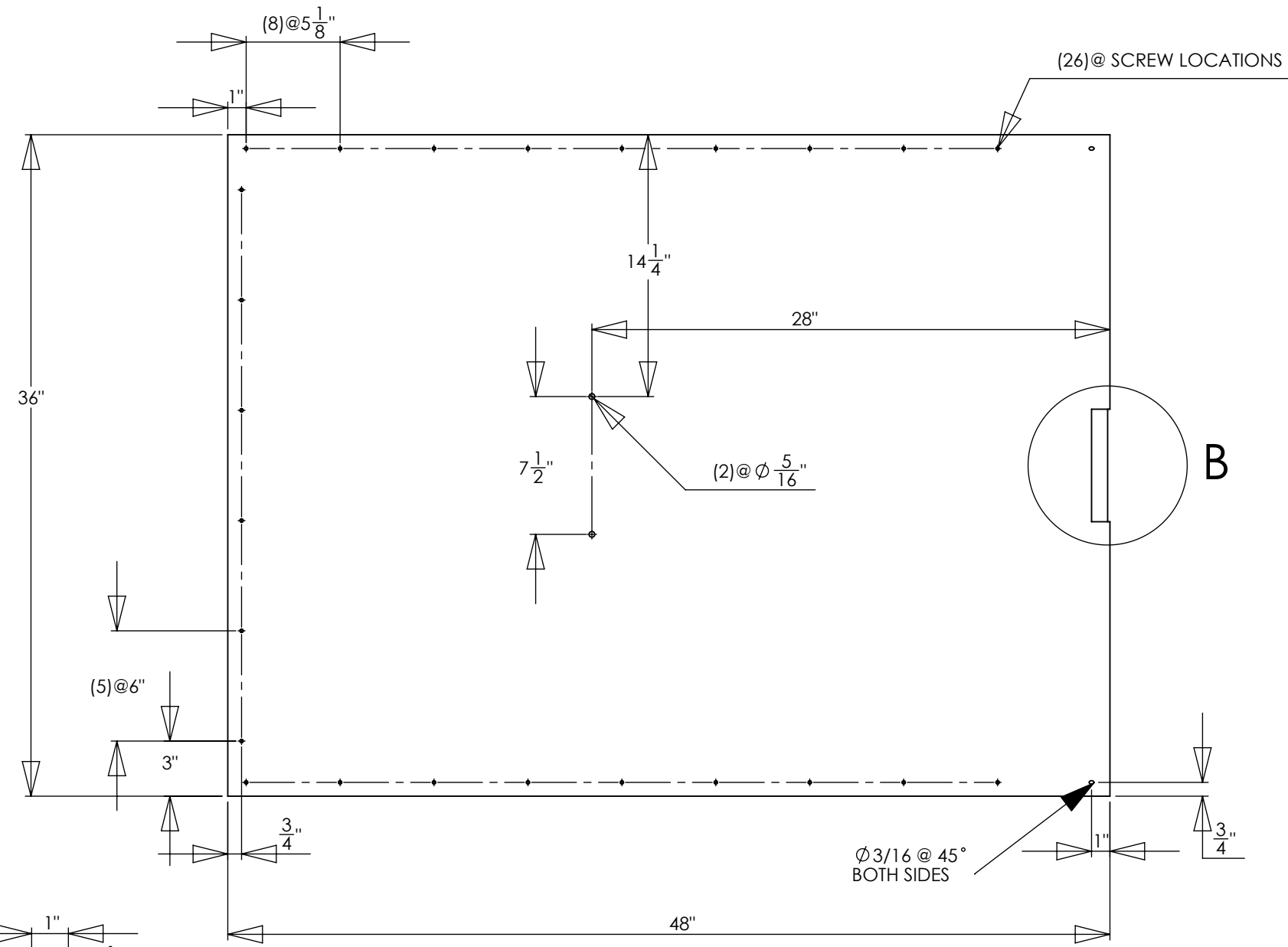

DETAIL B
SCALE 1 : 4

PROPRIETARY AND CONFIDENTIAL
THE INFORMATION CONTAINED IN THIS DRAWING IS THE SOLE PROPERTY OF National Horseshoe Pitcher's Association. ANY REPRODUCTION IN PART OR AS A WHOLE WITHOUT THE WRITTEN PERMISSION OF National Horseshoe Pitcher's Association IS PROHIBITED.

		UNLESS OTHERWISE SPECIFIED:		NAME	DATE	 NATIONAL HORSESHOE PITCHER'S ASSOCIATION
		DIMENSIONS ARE IN INCHES TOLERANCES: FRACTIONAL ± ANGULAR: MACH ± BEND ± TWO PLACE DECIMAL ± THREE PLACE DECIMAL ±		DRAWN	6/25/08	
		INTERPRET GEOMETRIC TOLERANCING PER:		CHECKED		TITLE:
		MATERIAL		ENG APPR.		BASE ASSEMBLY PLYWOOD
		3/4 PLYWOOD		MFG APPR.		SIZE
		FINISH		Q.A.		B
NEXT ASSY	USED ON			COMMENTS:		DWG. NO.
						BAPW
APPLICATION		DO NOT SCALE DRAWING				REV
						SCALE: 1:8
						WEIGHT:
						SHEET 2 OF 4

8 7 6 5 4 3 2 1

8 7 6 5 4 3 2 1

D

C

B

A

D

C

B

A

SIDE BOARD
2" X 4" LUMBER

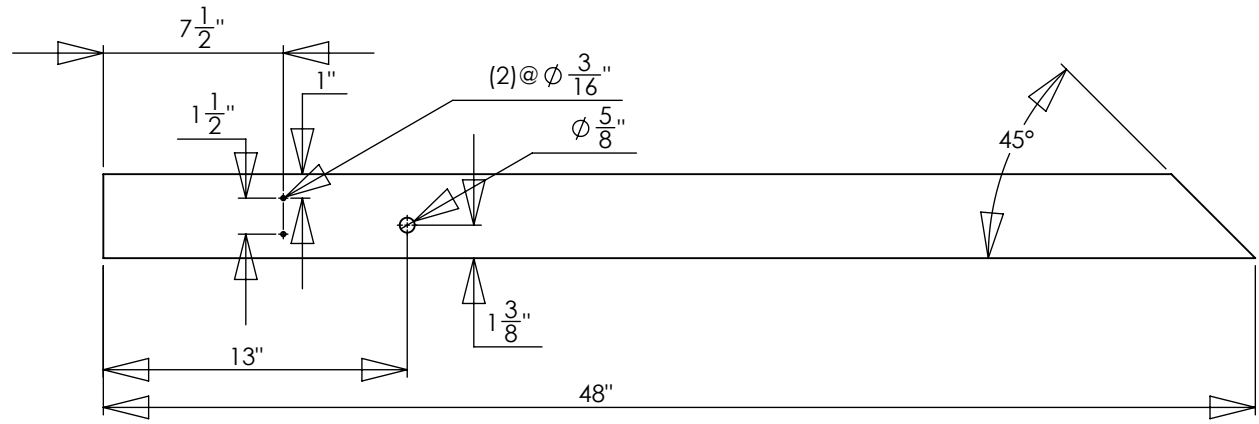

CORNER ANGLE FLAT

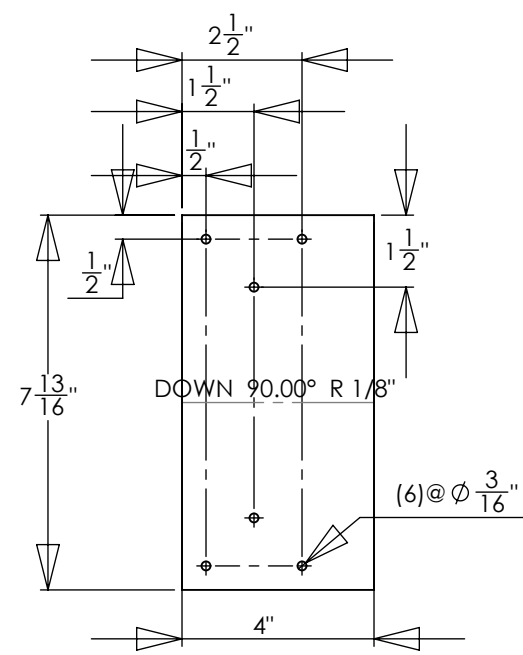

CORNER ANGLE

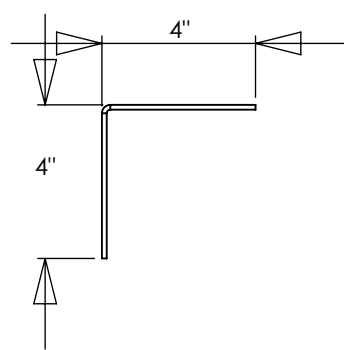

BACK BOARD
2" X 4" LUMBER

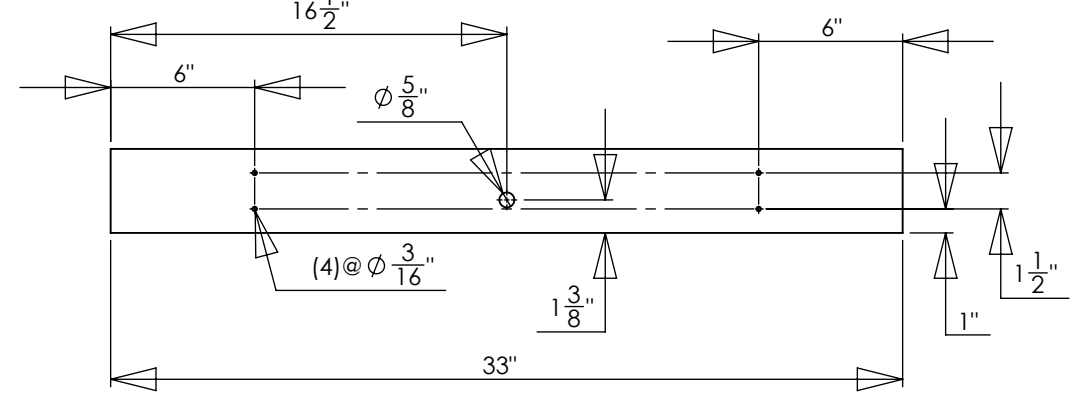

ALUMINUM CHANNEL

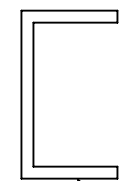
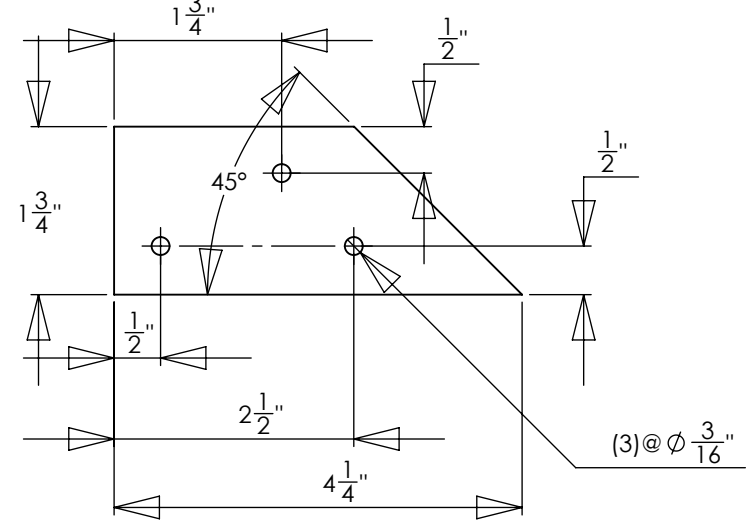

THERE IS A LEFT AND RIGHT VERSIONS OF THIS PART

PROPRIETARY AND CONFIDENTIAL
THE INFORMATION CONTAINED IN THIS DRAWING IS THE SOLE PROPERTY OF National Horseshoe Pitcher's Association. ANY REPRODUCTION IN PART OR AS A WHOLE WITHOUT THE WRITTEN PERMISSION OF National Horseshoe Pitcher's Association IS PROHIBITED.

		UNLESS OTHERWISE SPECIFIED:		NAME	DATE	 NATIONAL HORSESHOE PITCHER'S ASSOCIATION
		DIMENSIONS ARE IN INCHES TOLERANCES: FRACTIONAL ± ANGULAR: MACH ± BEND ± TWO PLACE DECIMAL ± THREE PLACE DECIMAL ±		DRAWN	CAR	
		INTERPRET GEOMETRIC TOLERANCING PER:		CHECKED		TITLE:
		MATERIAL SEE PART LIST		ENG APPR.		BASE ASSEMBLY DETAILS
		FINISH		MFG APPR.		
NEXT ASSY	USED ON			Q.A.		DWG. NO.
APPLICATION		DO NOT SCALE DRAWING		COMMENTS:		REV
						SCALE: 1:8
						WEIGHT:
						SHEET 3 OF 4

8 7 6 5 4 3 2 1

ITEM NO.	PART NUMBER	DESCRIPTION	QTY.
1	PLYWOOD BASE	3/4" PLYWOOD 48" X 36"	1
2	SIDE 2X4	2" X 4" LUMBER X 48" 45° ONE END	2
3	BACK BOARD	2" X 4" LUMBER X 33"	1
4	ALUM CHANNEL	ALUMINUM CHANNEL 1-3/4" X 1" X 1/8" X 4-1/4" 45° ONE END SEE SHEET 3	1
5	LEFT ALUM CHANNEL	ALUMINUM CHANNEL 1-3/4" X 1" X 1/8" X 4-1/4" 45° ONE END SEE SHEET 3	1
6	CR-FHMS 0.19-24x1.5x2.5-N	#10 COATED DECK SCREWS 2-1/2"	26
7	CR-FHMS 0.19-24x1.5x1.5-N	#10 COATED DECK SCREWS 1-1/2"	26
8	CONNER ANGLE	1/8" FLAT STEEL 7-13/16" X 4"	2
9	CONNER BOARD	2" X 4" LUMBER X 10" 45° ON BOTH ENDS	2

D

D

C

C

B

B

A

A

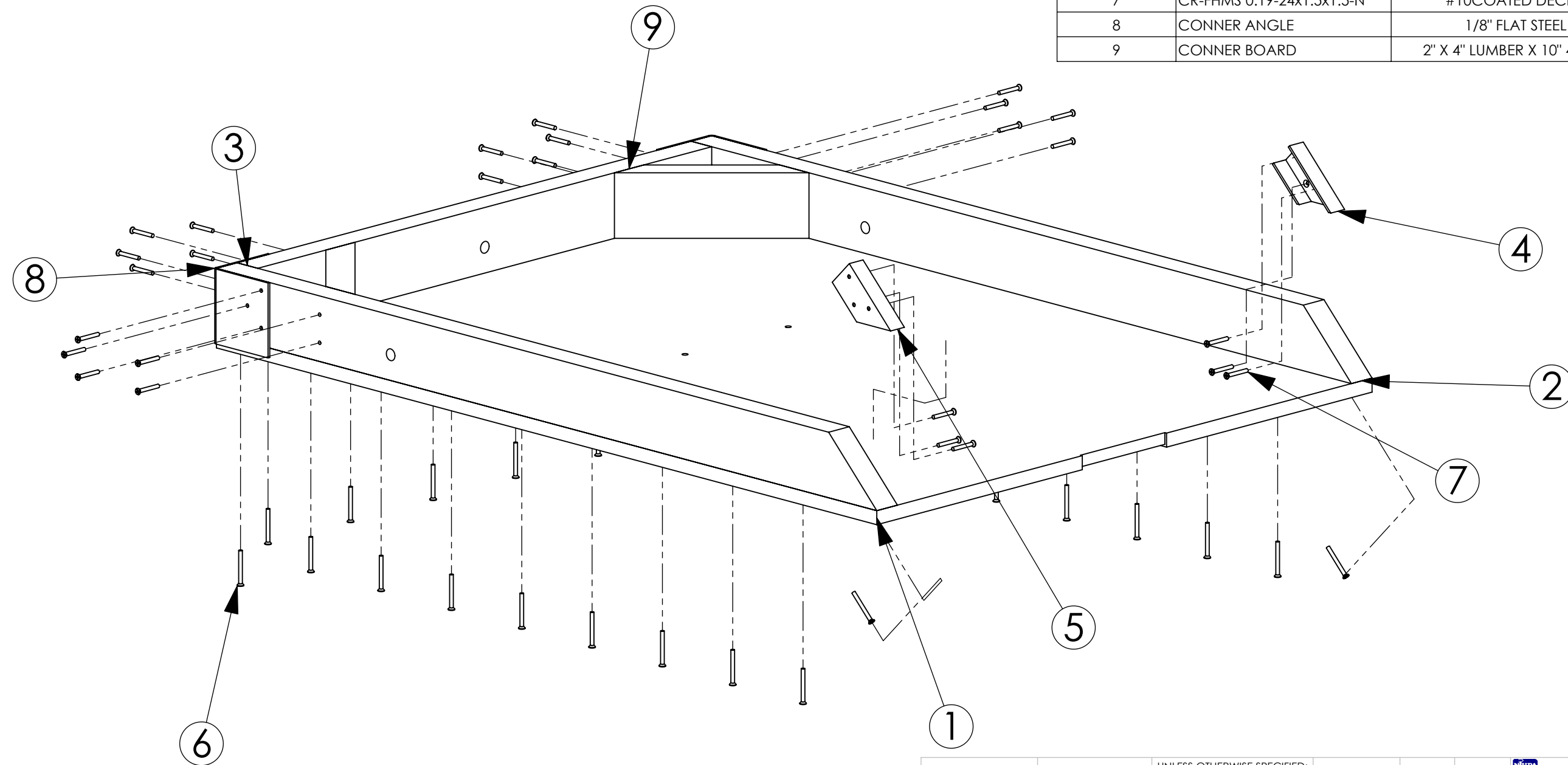

PROPRIETARY AND CONFIDENTIAL
 THE INFORMATION CONTAINED IN THIS DRAWING IS THE SOLE PROPERTY OF National Horseshoe Pitcher's Association. ANY REPRODUCTION IN PART OR AS A WHOLE WITHOUT THE WRITTEN PERMISSION OF National Horseshoe Pitcher's Association IS PROHIBITED.

		UNLESS OTHERWISE SPECIFIED:				NAME		DATE		 NATIONAL HORSESHOE PITCHER'S ASSOCIATION	
		DIMENSIONS ARE IN INCHES		DRAWN		CAR		6/25/08		TITLE:	
		TOLERANCES:		CHECKED						BASE ASSEMBLY PART LIST	
		FRACTIONAL ±		ENG APPR.						SIZE	
		ANGULAR: MACH ± BEND ±		MFG APPR.						DWG. NO.	
		TWO PLACE DECIMAL ±		Q.A.						REV	
		THREE PLACE DECIMAL ±		COMMENTS:						B	
		INTERPRET GEOMETRIC TOLERANCING PER:								BAP	
		MATERIAL		NEXT ASSY		USED ON				SCALE: 1:6	
		SEE PART LIST								WEIGHT:	
		FINISH		APPLICATION		DO NOT SCALE DRAWING				SHEET 4 OF 4	

8

7

6

5

4

3

2

1

8

7

6

5

4

3

2

1

8 7 6 5 4 3 2 1

D

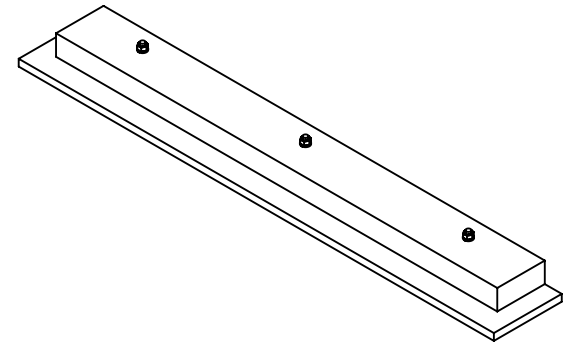
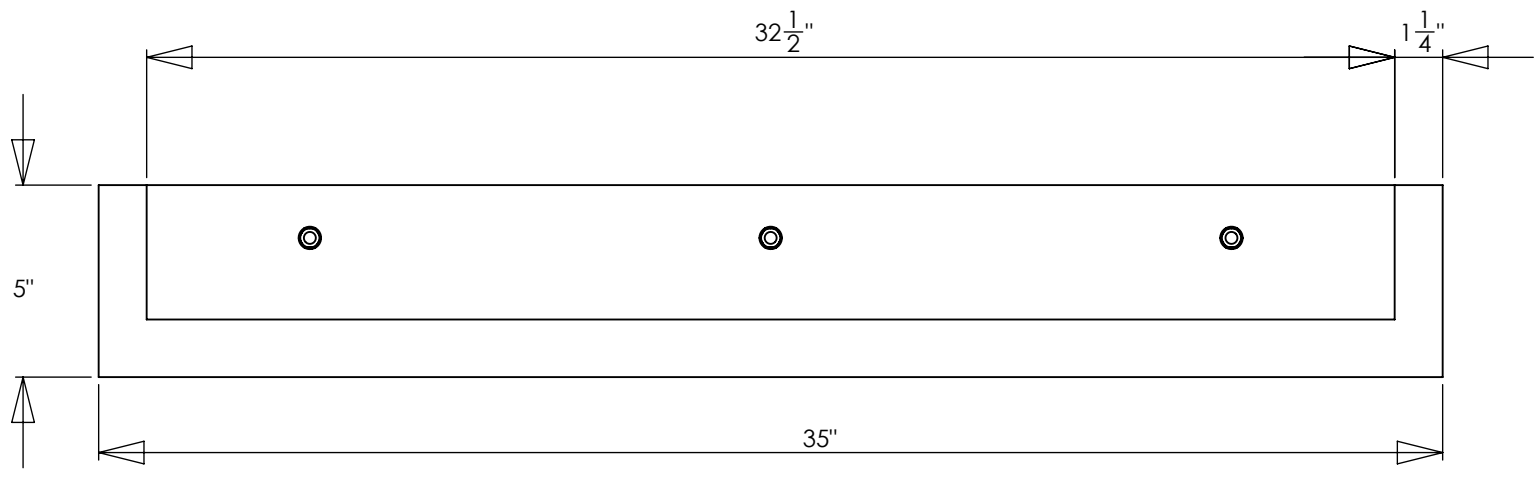

D

C

C

B

B

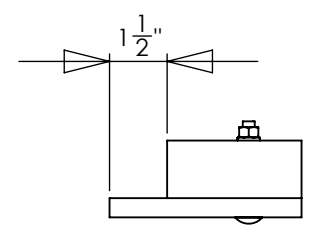
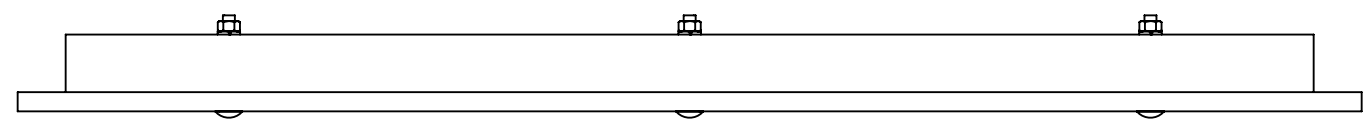

A

A

PROPRIETARY AND CONFIDENTIAL
 THE INFORMATION CONTAINED IN THIS DRAWING IS THE SOLE PROPERTY OF National Horseshoe Pitcher's Association. ANY REPRODUCTION IN PART OR AS A WHOLE WITHOUT THE WRITTEN PERMISSION OF National Horseshoe Pitcher's Association IS PROHIBITED.

		UNLESS OTHERWISE SPECIFIED:		NAME	DATE	 NATIONAL HORSESHOE PITCHER'S ASSOCIATION TITLE: <h1>FRONT BUMPER BOARD</h1>	
		DIMENSIONS ARE IN INCHES		DRAWN	CAR		6/24/08
		TOLERANCES:		CHECKED			
		FRACTIONAL ±		ENG APPR.			
		ANGULAR: MACH ± BEND ±		MFG APPR.			
		TWO PLACE DECIMAL ±		Q.A.			
		THREE PLACE DECIMAL ±		COMMENTS:			
		INTERPRET GEOMETRIC TOLERANCING PER:					
		MATERIAL				SIZE	
		SEE PART LIST				DWG. NO.	
		FINISH				REV	
NEXT ASSY	USED ON						
APPLICATION		DO NOT SCALE DRAWING				SCALE: 1:5	
						WEIGHT:	
						SHEET 1 OF 3	

8 7 6 5 4 3 2 1

8 7 6 5 4 3 2 1

D

D

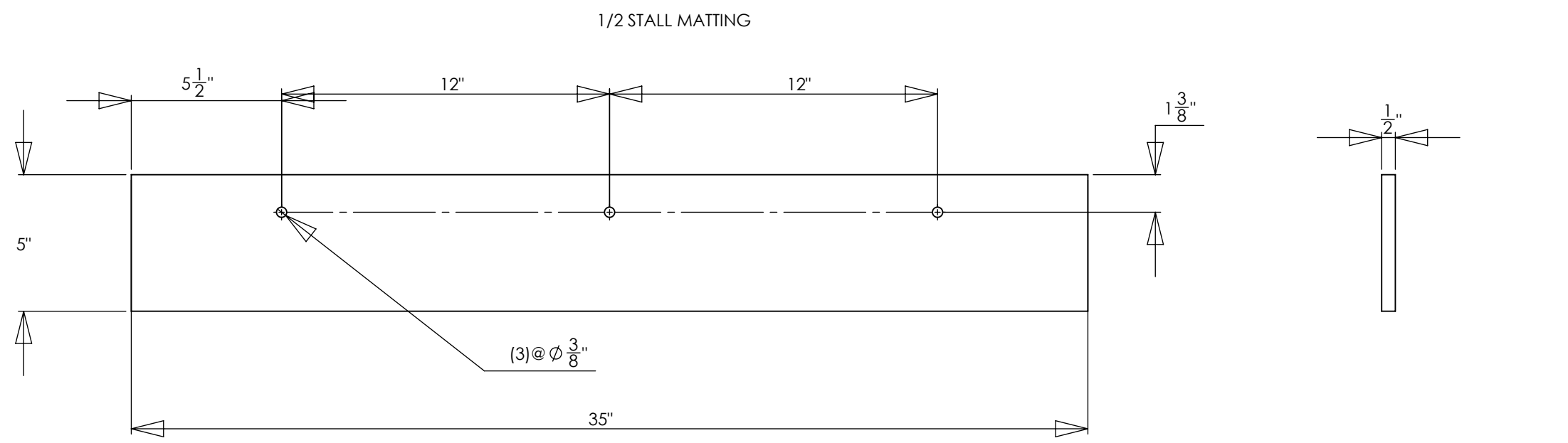

C

C

STANDARD 2X4 LUMBER

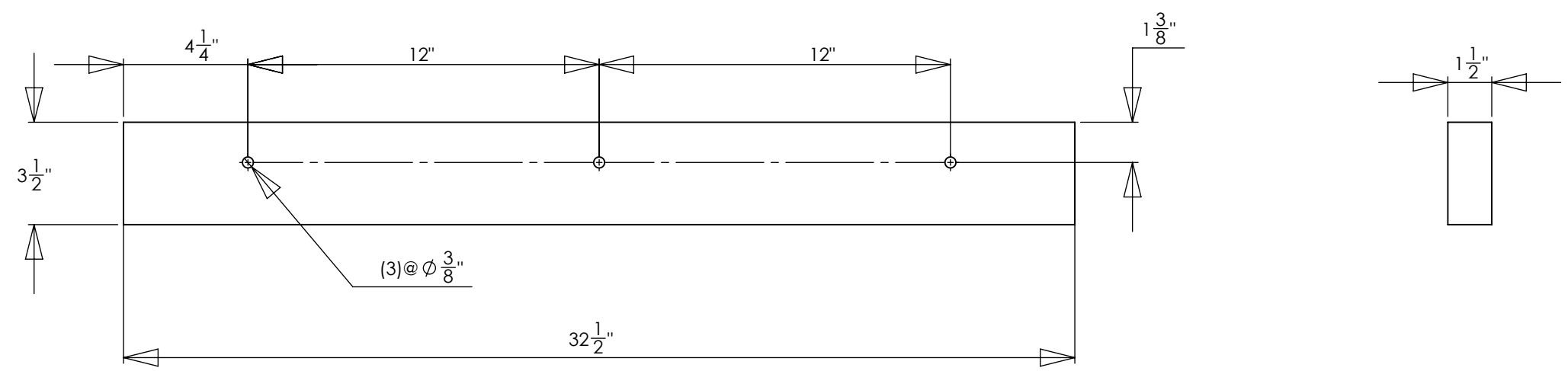

B

B

A

A

PROPRIETARY AND CONFIDENTIAL
 THE INFORMATION CONTAINED IN THIS DRAWING IS THE SOLE PROPERTY OF National Horseshoe Pitcher's Association. ANY REPRODUCTION IN PART OR AS A WHOLE WITHOUT THE WRITTEN PERMISSION OF National Horseshoe Pitcher's Association IS PROHIBITED.

		UNLESS OTHERWISE SPECIFIED:		NAME	DATE	 NATIONAL HORSESHOE PITCHER'S ASSOCIATION TITLE: <h1>FRONT BUMPER BOARD DETAILS</h1>	
		DIMENSIONS ARE IN INCHES		DRAWN	CAR		6/24/08
		TOLERANCES:		CHECKED			
		FRACTIONAL ±		ENG APPR.			
		ANGULAR: MACH ± BEND ±		MFG APPR.			
		TWO PLACE DECIMAL ±		Q.A.			
		THREE PLACE DECIMAL ±		COMMENTS:			
		INTERPRET GEOMETRIC TOLERANCING PER:					
		MATERIAL				SIZE DWG. NO. REV	
		SEE PART LIST				B FBBD	
		FINISH				SCALE: 1:5 WEIGHT: SHEET 2 OF 3	
NEXT ASSY	USED ON	DO NOT SCALE DRAWING					
APPLICATION							

8 7 6 5 4 3 2 1

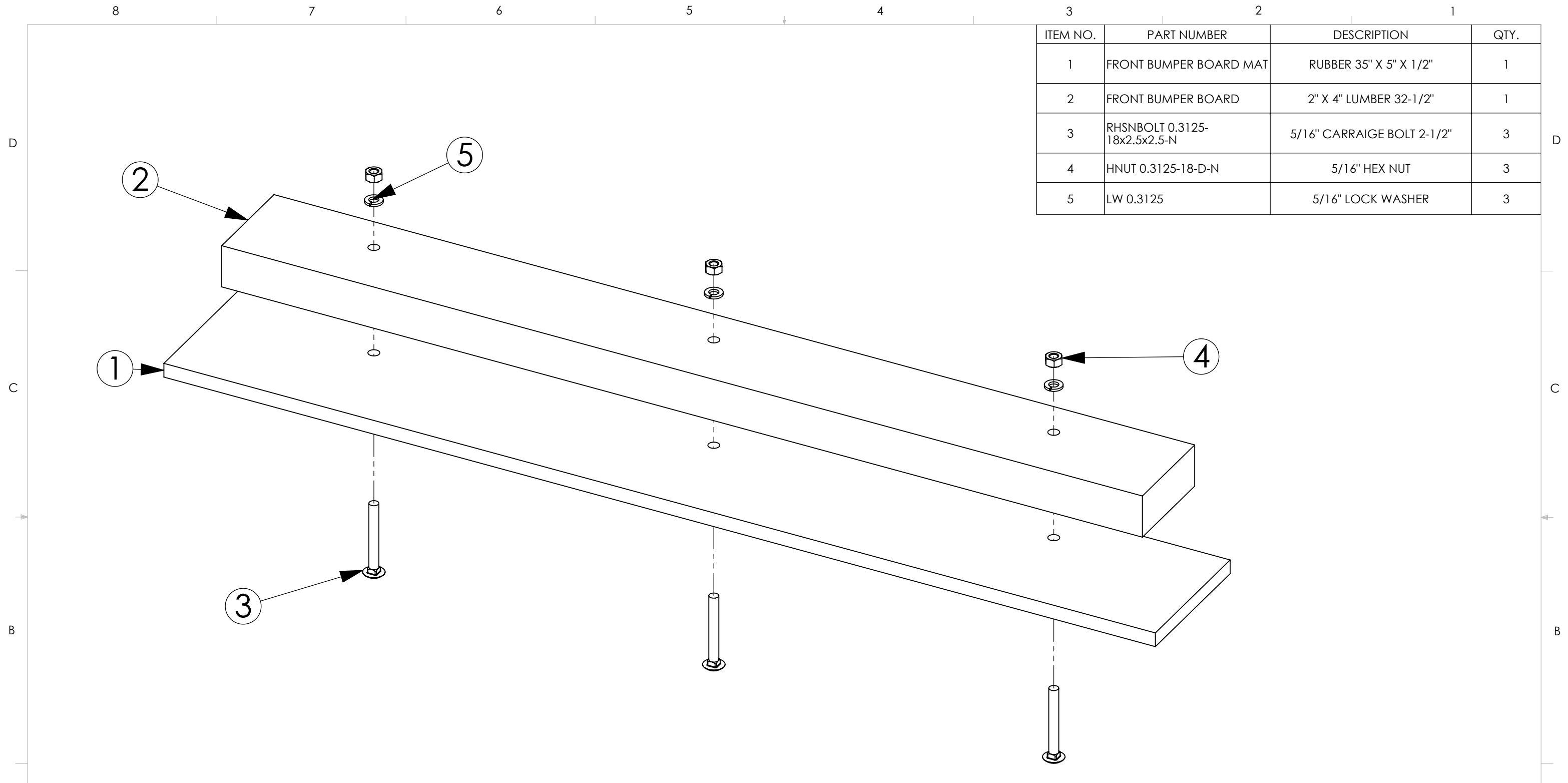

ITEM NO.	PART NUMBER	DESCRIPTION	QTY.
1	FRONT BUMPER BOARD MAT	RUBBER 35" X 5" X 1/2"	1
2	FRONT BUMPER BOARD	2" X 4" LUMBER 32-1/2"	1
3	RHSNBOLT 0.3125-18x2.5x2.5-N	5/16" CARRAIGE BOLT 2-1/2"	3
4	HNUT 0.3125-18-D-N	5/16" HEX NUT	3
5	LW 0.3125	5/16" LOCK WASHER	3

PROPRIETARY AND CONFIDENTIAL
 THE INFORMATION CONTAINED IN THIS DRAWING IS THE SOLE PROPERTY OF National Horseshoe Pitcher's Association. ANY REPRODUCTION IN PART OR AS A WHOLE WITHOUT THE WRITTEN PERMISSION OF National Horseshoe Pitcher's Association IS PROHIBITED.

		UNLESS OTHERWISE SPECIFIED:		NAME		DATE		 NATIONAL HORSESHOE PITCHER'S ASSOCIATION	
		DIMENSIONS ARE IN INCHES		DRAWN		CAR			FRONT BUMPER BOARD PARTS
		TOLERANCES:		CHECKED					
		FRACTIONAL ±		ENG APPR.					
		ANGULAR: MACH ± BEND ±		MFG APPR.					
		TWO PLACE DECIMAL ±		Q.A.					
		THREE PLACE DECIMAL ±		COMMENTS:				SIZE B DWG. NO. FBBP REV	
INTERPRET GEOMETRIC TOLERANCING PER:		MATERIAL		FINISH		SCALE: 1:3		WEIGHT:	
NEXT ASSY USED ON		SEE PART LIST		DO NOT SCALE DRAWING		SHEET 3 OF 3			

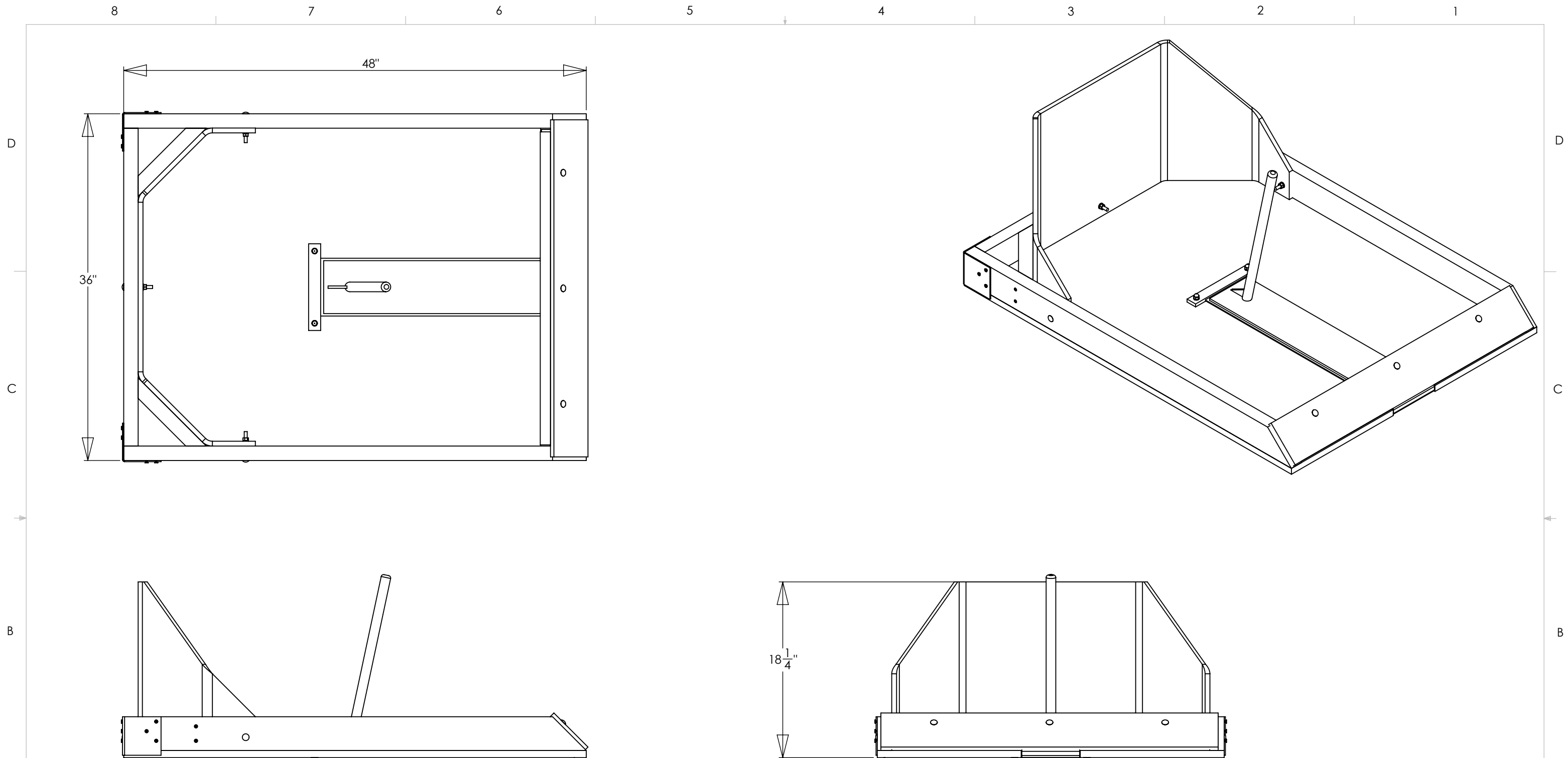

PROPRIETARY AND CONFIDENTIAL
 THE INFORMATION CONTAINED IN THIS DRAWING IS THE SOLE PROPERTY OF National Horseshoe Pitcher's Association. ANY REPRODUCTION IN PART OR AS A WHOLE WITHOUT THE WRITTEN PERMISSION OF National Horseshoe Pitcher's Association IS PROHIBITED.

		UNLESS OTHERWISE SPECIFIED:		NAME	DATE	 NATIONAL HORSESHOE PITCHER'S ASSOCIATION
		DIMENSIONS ARE IN INCHES TOLERANCES: FRACTIONAL ± ANGULAR: MACH ± BEND ± TWO PLACE DECIMAL ± THREE PLACE DECIMAL ±		DRAWN	CAR	
		INTERPRET GEOMETRIC TOLERANCING PER:		CHECKED		TITLE:
		MATERIAL SEE PART LIST		ENG APPR.		HORSESHOE PIT ASSEMBLY
		FINISH		MFG APPR.		
NEXT ASSY	USED ON			Q.A.		DWG. NO.
APPLICATION		DO NOT SCALE DRAWING		COMMENTS:		REV
						SCALE: 1:10
						WEIGHT:
						SHEET 1 OF 4

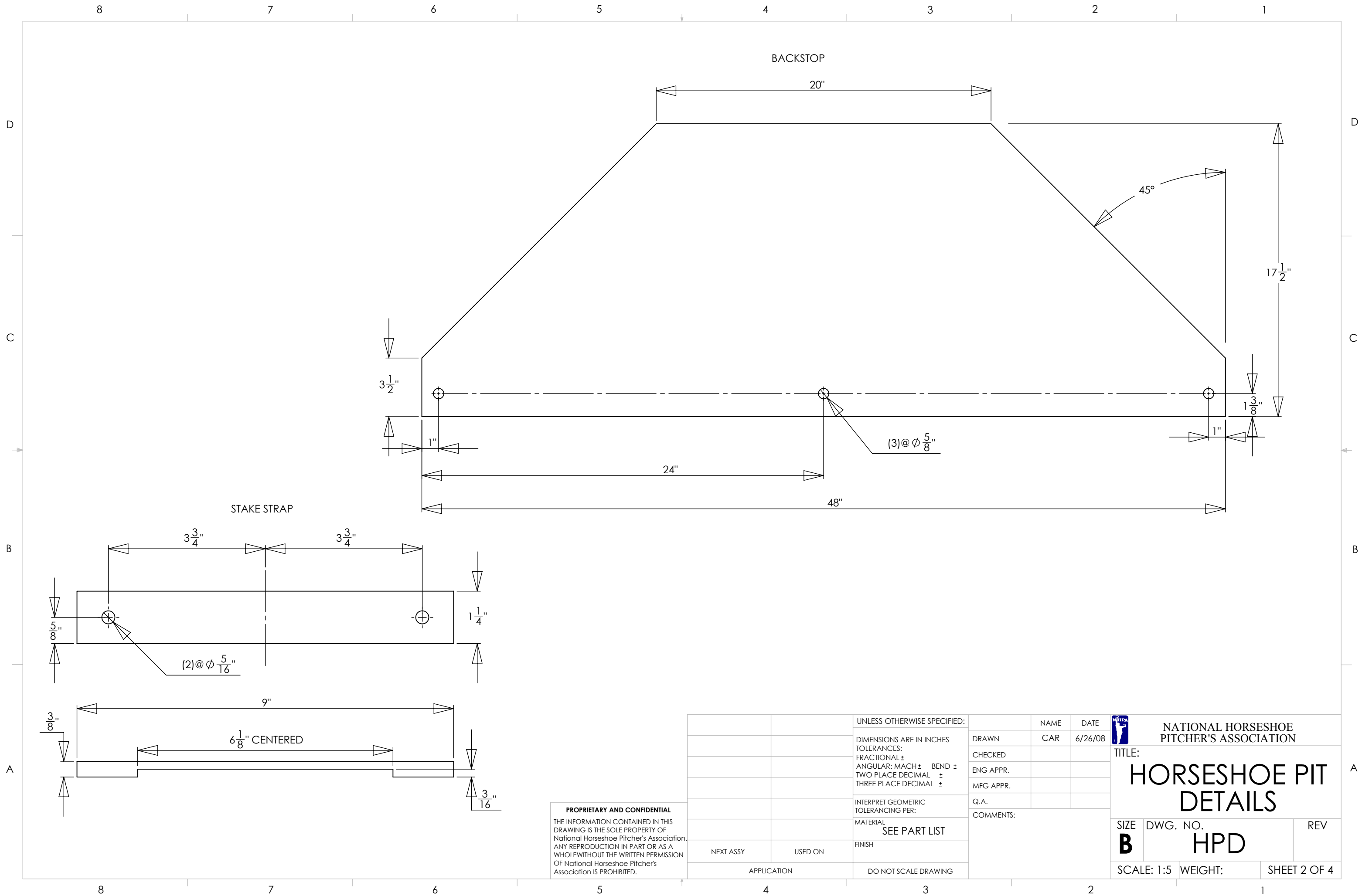

PROPRIETARY AND CONFIDENTIAL
 THE INFORMATION CONTAINED IN THIS DRAWING IS THE SOLE PROPERTY OF National Horseshoe Pitcher's Association. ANY REPRODUCTION IN PART OR AS A WHOLE WITHOUT THE WRITTEN PERMISSION OF National Horseshoe Pitcher's Association IS PROHIBITED.

		UNLESS OTHERWISE SPECIFIED:		NAME	DATE	 NATIONAL HORSESHOE PITCHER'S ASSOCIATION
		DIMENSIONS ARE IN INCHES TOLERANCES: FRACTIONAL ± ANGULAR: MACH ± BEND ± TWO PLACE DECIMAL ± THREE PLACE DECIMAL ±		DRAWN	CAR	
		INTERPRET GEOMETRIC TOLERANCING PER:		CHECKED		TITLE:
		MATERIAL SEE PART LIST		ENG APPR.		HORSESHOE PIT DETAILS
		FINISH		MFG APPR.		
NEXT ASSY	USED ON			Q.A.		DWG. NO.
APPLICATION		DO NOT SCALE DRAWING		COMMENTS:		REV
						SCALE: 1:5
						WEIGHT:
						SHEET 2 OF 4

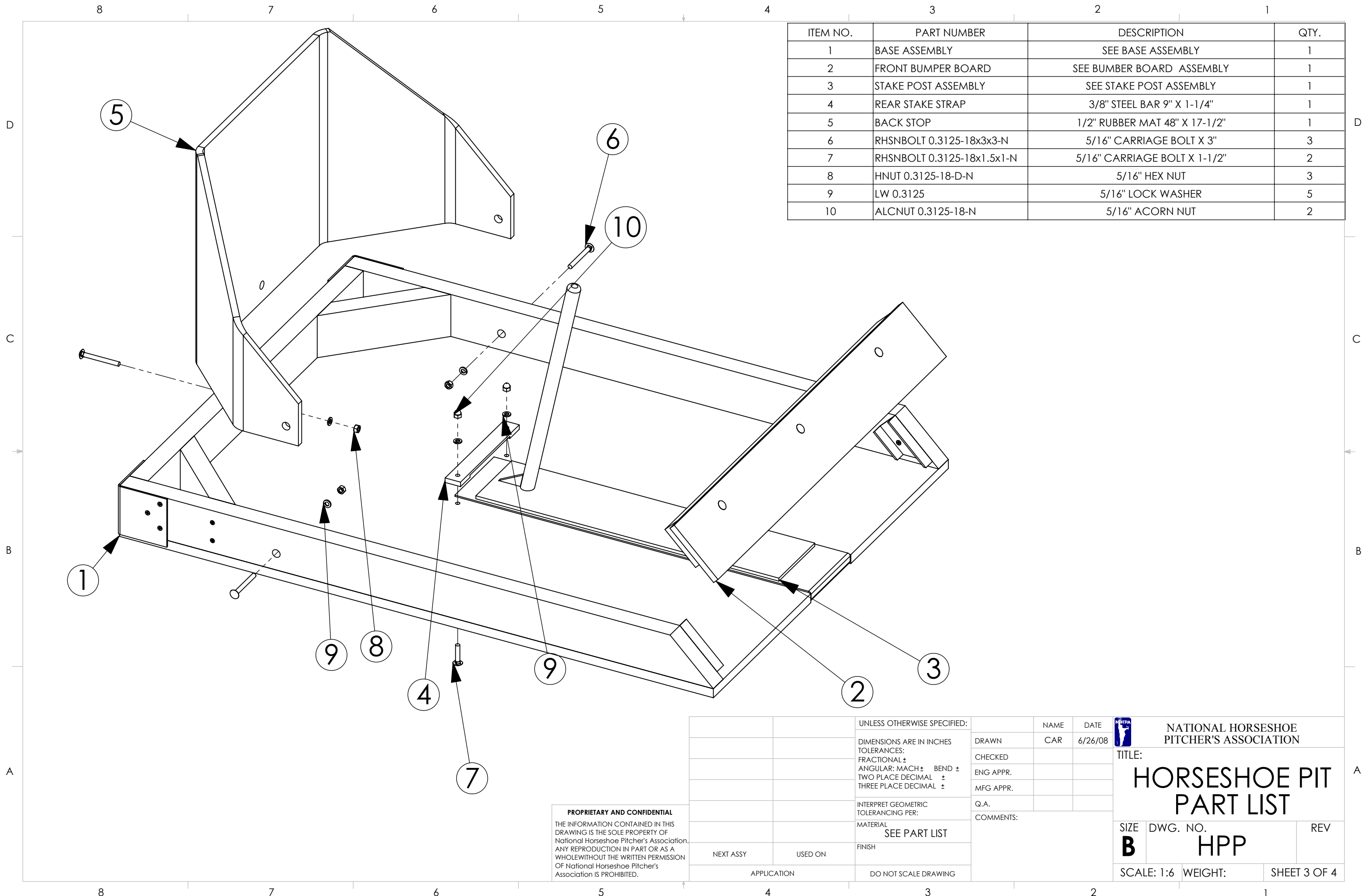

ITEM NO.	PART NUMBER	DESCRIPTION	QTY.
1	BASE ASSEMBLY	SEE BASE ASSEMBLY	1
2	FRONT BUMPER BOARD	SEE BUMPER BOARD ASSEMBLY	1
3	STAKE POST ASSEMBLY	SEE STAKE POST ASSEMBLY	1
4	REAR STAKE STRAP	3/8" STEEL BAR 9" X 1-1/4"	1
5	BACK STOP	1/2" RUBBER MAT 48" X 17-1/2"	1
6	RHSNBOLT 0.3125-18x3x3-N	5/16" CARRIAGE BOLT X 3"	3
7	RHSNBOLT 0.3125-18x1.5x1-N	5/16" CARRIAGE BOLT X 1-1/2"	2
8	HNUT 0.3125-18-D-N	5/16" HEX NUT	3
9	LW 0.3125	5/16" LOCK WASHER	5
10	ALCNUT 0.3125-18-N	5/16" ACORN NUT	2

PROPRIETARY AND CONFIDENTIAL
 THE INFORMATION CONTAINED IN THIS DRAWING IS THE SOLE PROPERTY OF National Horseshoe Pitcher's Association. ANY REPRODUCTION IN PART OR AS A WHOLE WITHOUT THE WRITTEN PERMISSION OF National Horseshoe Pitcher's Association IS PROHIBITED.

UNLESS OTHERWISE SPECIFIED:		NAME	DATE	 NATIONAL HORSESHOE PITCHER'S ASSOCIATION
DIMENSIONS ARE IN INCHES TOLERANCES: FRACTIONAL ± ANGULAR: MACH ± BEND ± TWO PLACE DECIMAL ± THREE PLACE DECIMAL ±		DRAWN	CAR	
INTERPRET GEOMETRIC TOLERANCING PER:		CHECKED		TITLE:
MATERIAL SEE PART LIST		ENG APPR.		HORSESHOE PIT PART LIST
FINISH		MFG APPR.		SIZE
NEXT ASSY	USED ON	Q.A.		DWG. NO.
APPLICATION		COMMENTS:		HPP
DO NOT SCALE DRAWING				REV
				SCALE: 1:6
				WEIGHT:
				SHEET 3 OF 4

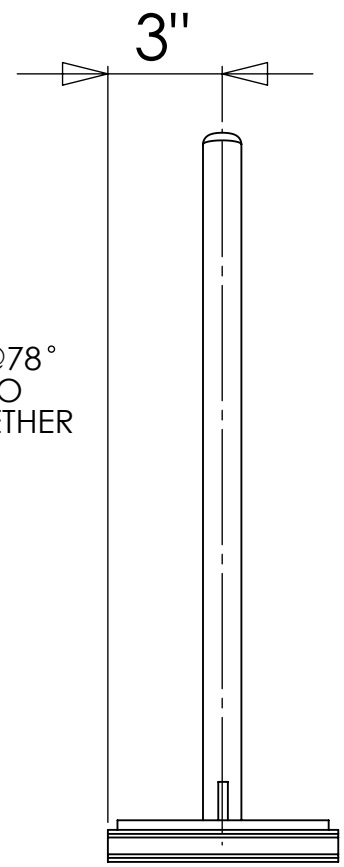
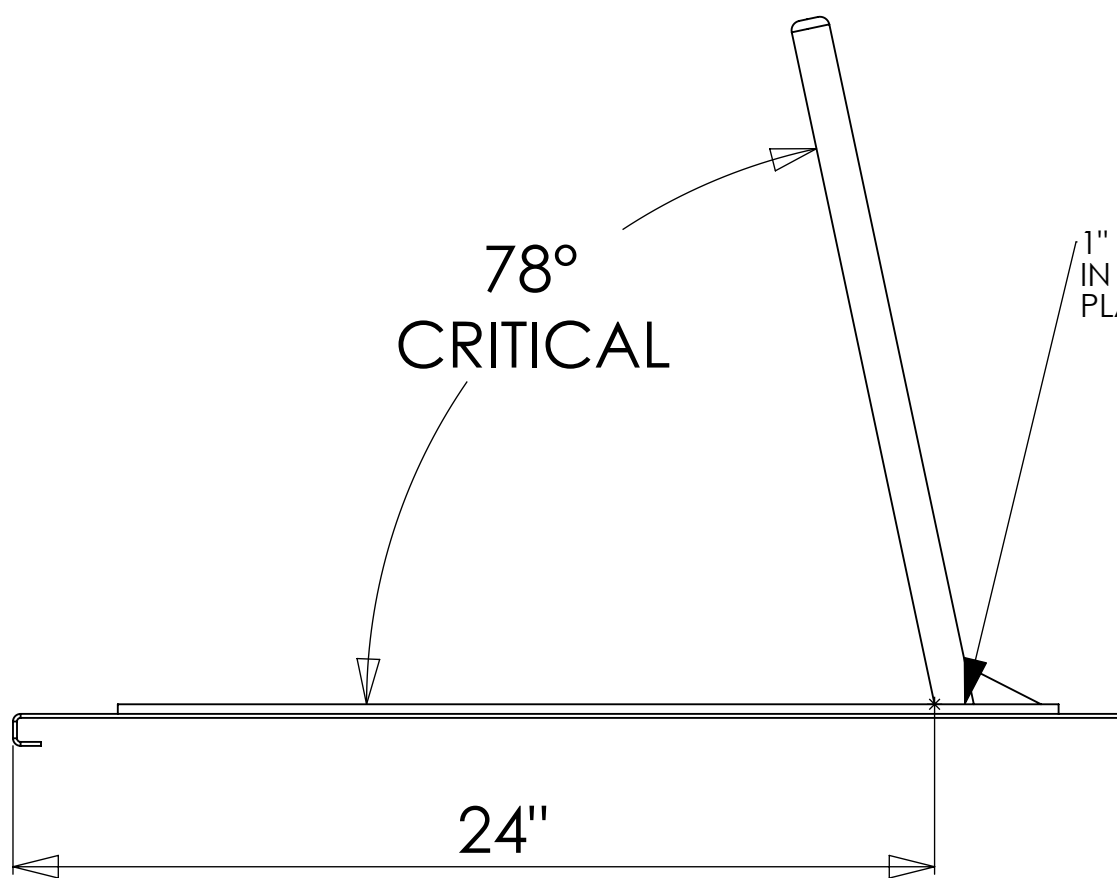
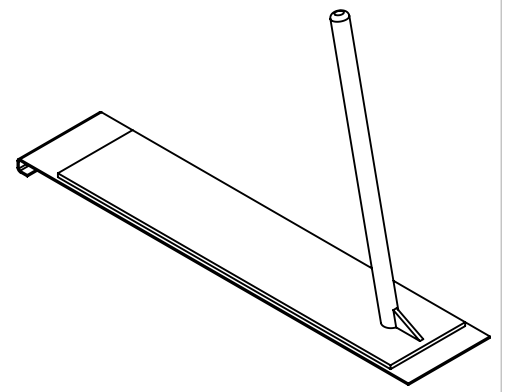
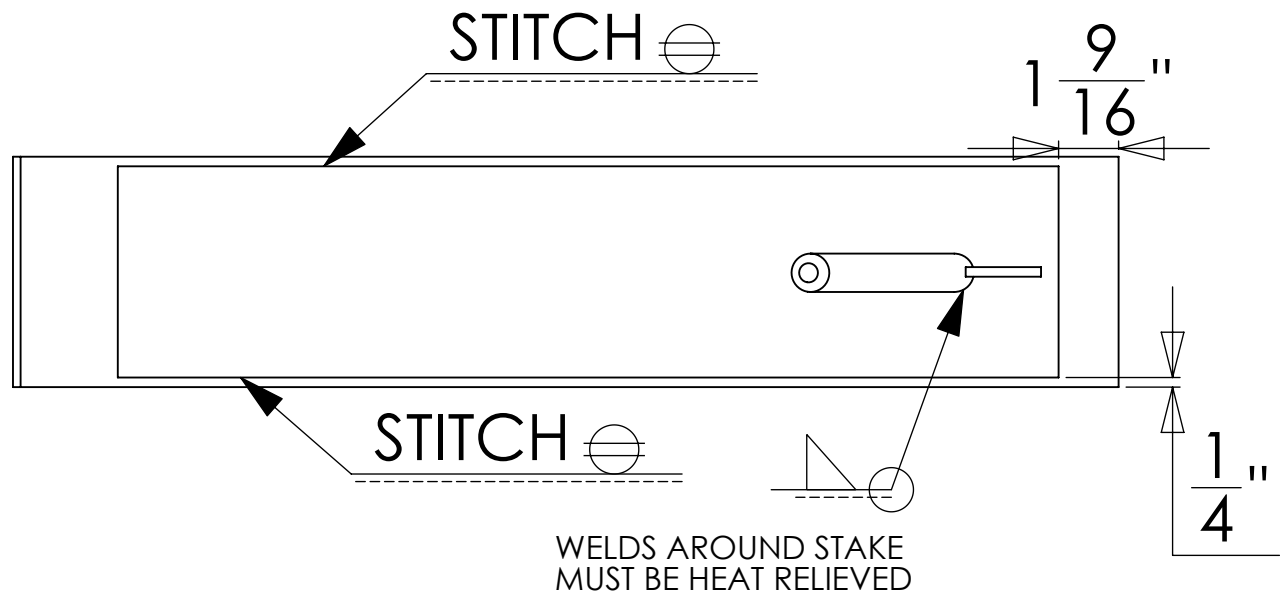

PROPRIETARY AND CONFIDENTIAL
 THE INFORMATION CONTAINED IN THIS DRAWING IS THE SOLE PROPERTY OF National Horseshoe Pitcher's Association. ANY REPRODUCTION IN PART OR AS A WHOLE WITHOUT THE WRITTEN PERMISSION OF National Horseshoe Pitcher's Association IS PROHIBITED.

		UNLESS OTHERWISE SPECIFIED:		NAME	DATE	 NATIONAL HORSESHOE PITCHER'S ASSOCIATION	
		DIMENSIONS ARE IN INCHES TOLERANCES: FRACTIONAL ± ANGULAR: MACH ± BEND ± TWO PLACE DECIMAL ± THREE PLACE DECIMAL ±		DRAWN	CAR		6/25/08
		INTERPRET GEOMETRIC TOLERANCING PER:		CHECKED			
		MATERIAL SEE PART LIST		ENG APPR.			
		FINISH		MFG APPR.			
NEXT ASSY	USED ON			Q.A.			
APPLICATION		DO NOT SCALE DRAWING		COMMENTS:			
				TITLE:		STAKE POST ASSEMBLY	
				SIZE	DWG. NO.		REV
				B	SPA		
				SCALE: 1:5		WEIGHT:	
						SHEET 1 OF 3	

8 7 6 5 4 3 2 1

BOTTOM PLATE FLAT

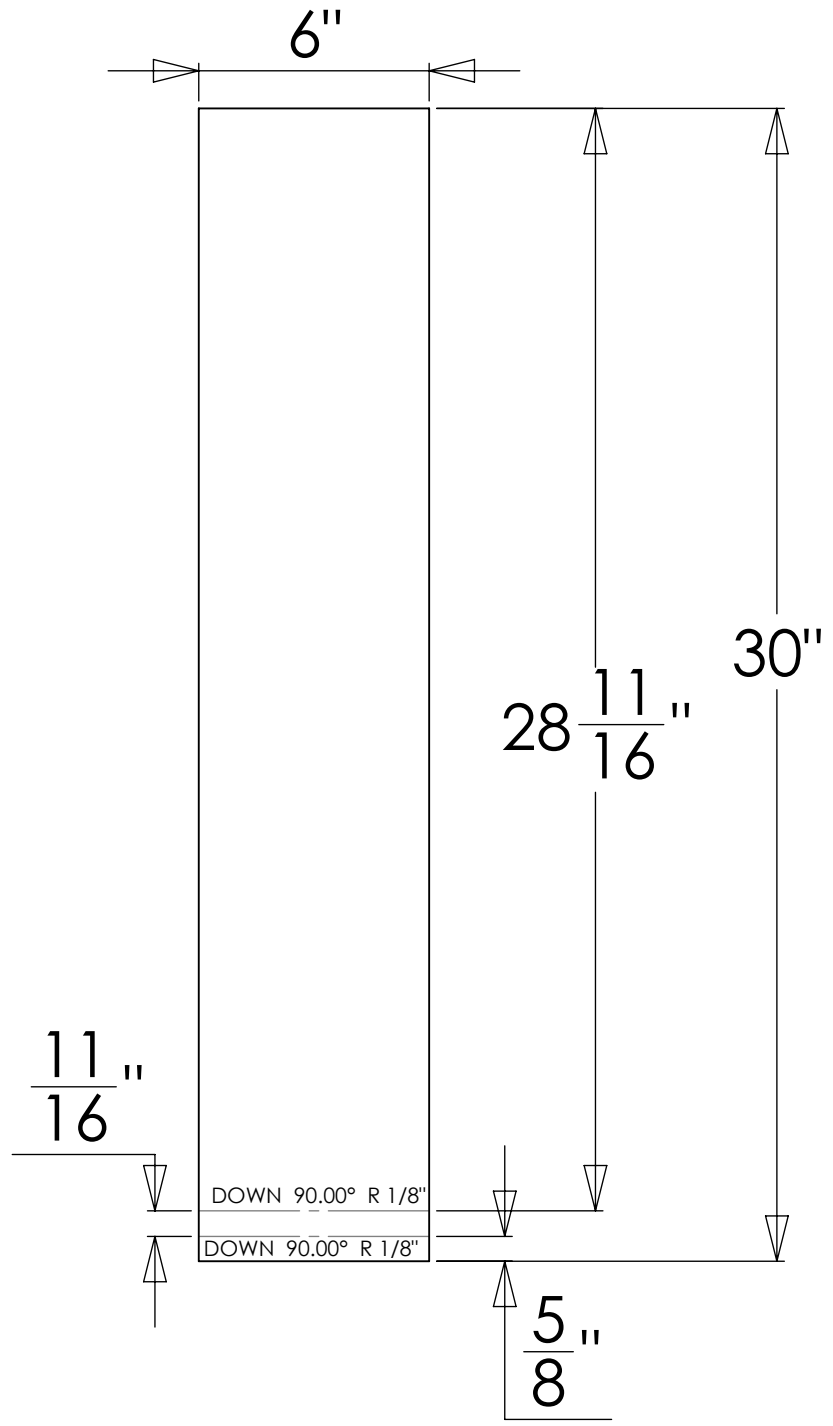

BOTTOM PLATE

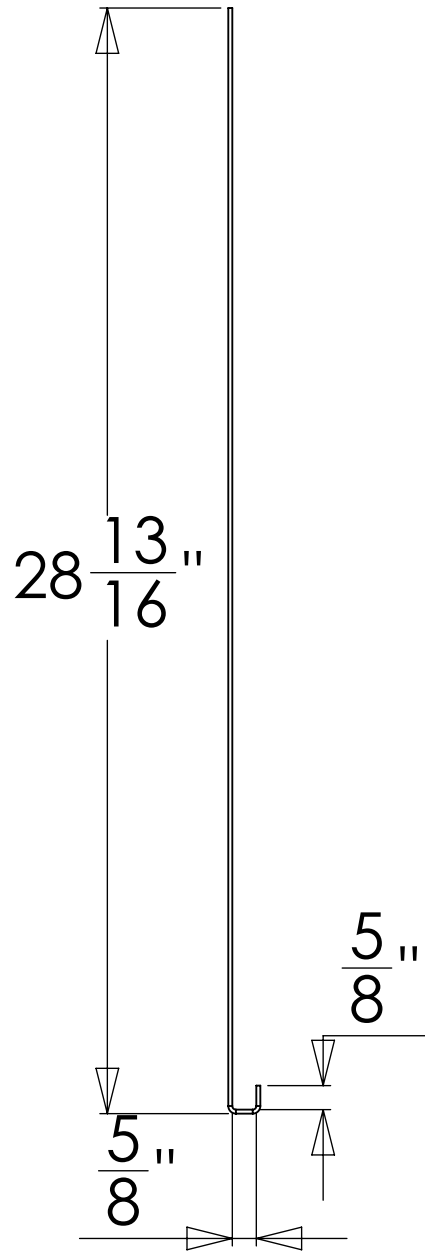

TOP PLATE

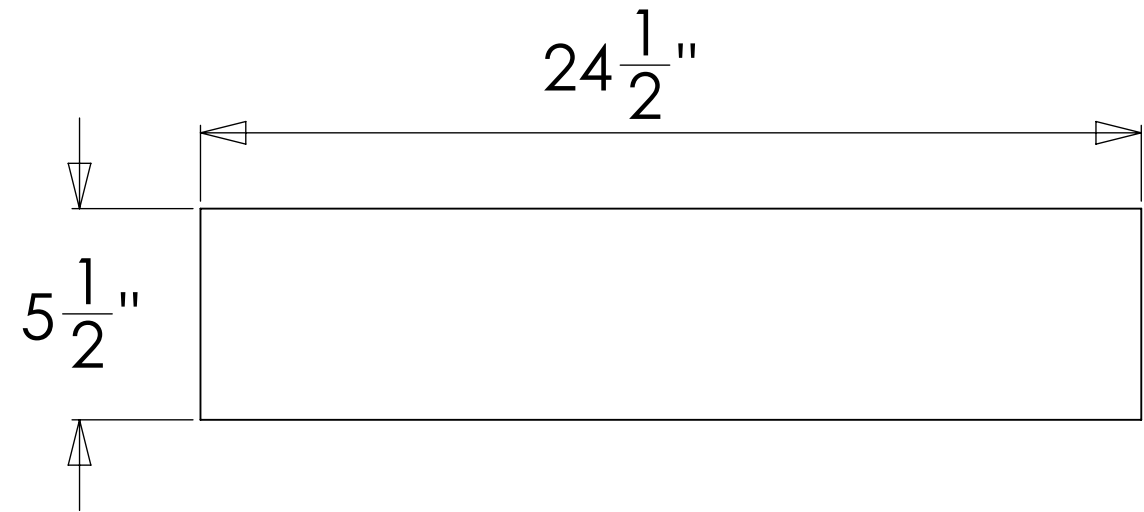

GUSSET

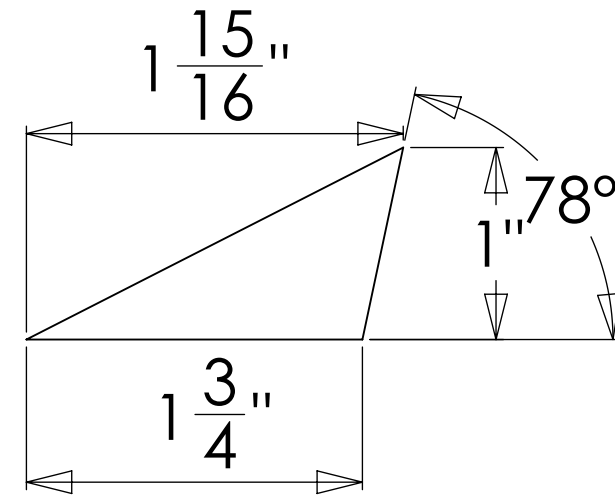

PROPRIETARY AND CONFIDENTIAL
 THE INFORMATION CONTAINED IN THIS DRAWING IS THE SOLE PROPERTY OF National Horseshoe Pitcher's Association. ANY REPRODUCTION IN PART OR AS A WHOLE WITHOUT THE WRITTEN PERMISSION OF National Horseshoe Pitcher's Association IS PROHIBITED.

		UNLESS OTHERWISE SPECIFIED:		NAME	DATE	 NATIONAL HORSESHOE PITCHER'S ASSOCIATION
		DIMENSIONS ARE IN INCHES TOLERANCES: FRACTIONAL ± ANGULAR: MACH ± BEND ± TWO PLACE DECIMAL ± THREE PLACE DECIMAL ±		DRAWN	CAR	
		INTERPRET GEOMETRIC TOLERANCING PER:		CHECKED		TITLE: <h1>STAKE POST DETAILS</h1>
		MATERIAL SEE PART LIST		ENG APPR.		
		FINISH		MFG APPR.		
NEXT ASSY	USED ON	DO NOT SCALE DRAWING		Q.A.		SIZE B DWG. NO. SPAD REV
APPLICATION				COMMENTS:		SCALE: 1:5 WEIGHT: SHEET 2 OF 3

8 7 6 5 4 3 2 1

