

**PROPRIETARY AND CONFIDENTIAL**  
 THE INFORMATION CONTAINED IN THIS DRAWING IS THE SOLE PROPERTY OF National Horseshoe Pitcher's Association. ANY REPRODUCTION IN PART OR AS A WHOLE WITHOUT THE WRITTEN PERMISSION OF National Horseshoe Pitcher's Association IS PROHIBITED.

		UNLESS OTHERWISE SPECIFIED:		NAME	DATE	 <b>NATIONAL HORSESHOE PITCHER'S ASSOCIATION</b>	
		DIMENSIONS ARE IN INCHES		DRAWN	CAR		6/25/08
		TOLERANCES:		CHECKED			
		FRACTIONAL ±		ENG APPR.			
		ANGULAR: MACH ± BEND ±		MFG APPR.			
		TWO PLACE DECIMAL ±		Q.A.			
		THREE PLACE DECIMAL ±		COMMENTS:			
		INTERPRET GEOMETRIC TOLERANCING PER:					
		MATERIAL					
		SEE PART LIST					
		FINISH					
NEXT ASSY	USED ON						
APPLICATION		DO NOT SCALE DRAWING					
				SIZE	DWG. NO.	REV	
				<b>B</b>	<b>SPA</b>		
				SCALE: 1:5	WEIGHT:	SHEET 1 OF 3	

8 7 6 5 4 3 2 1

BOTTOM PLATE FLAT

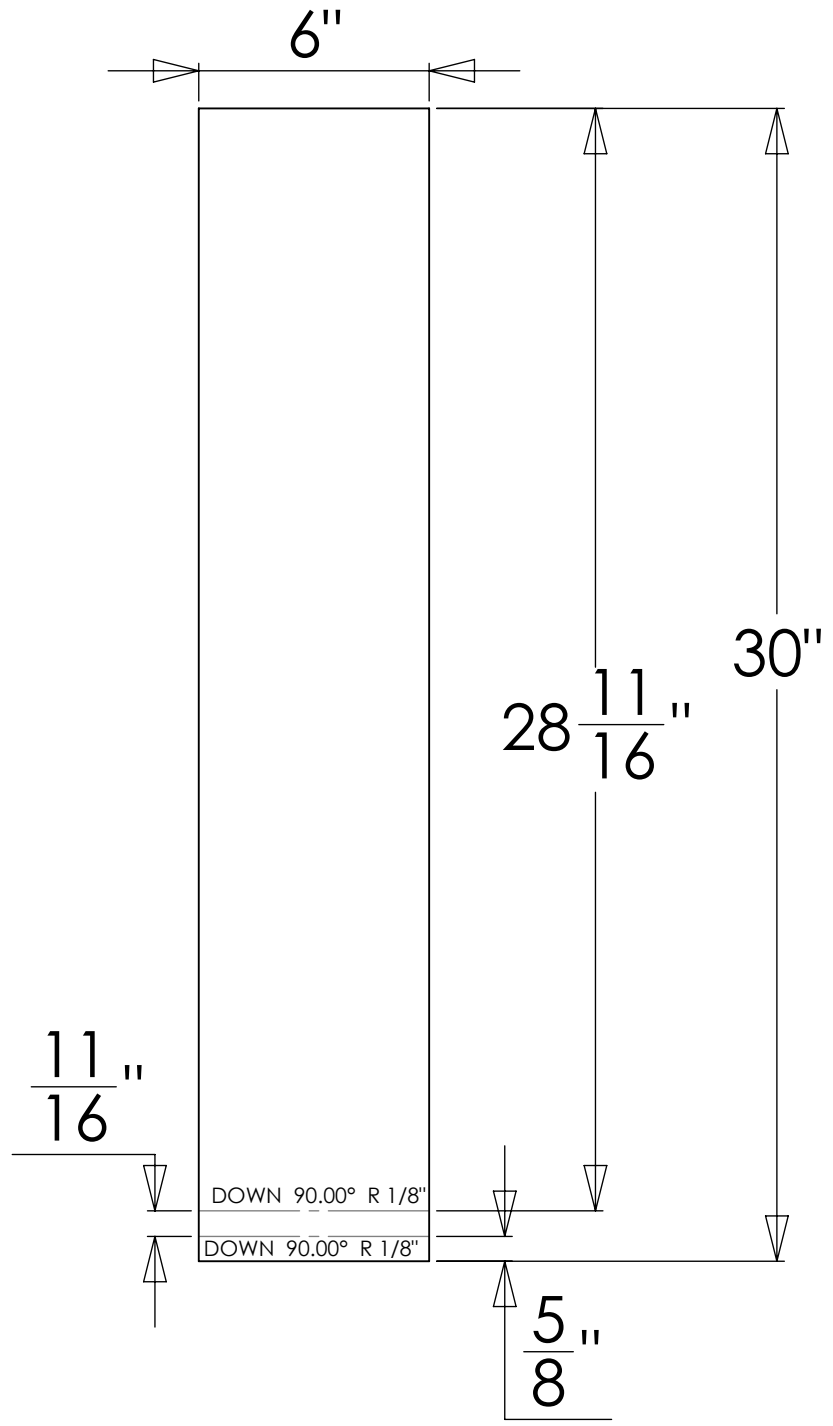

BOTTOM PLATE

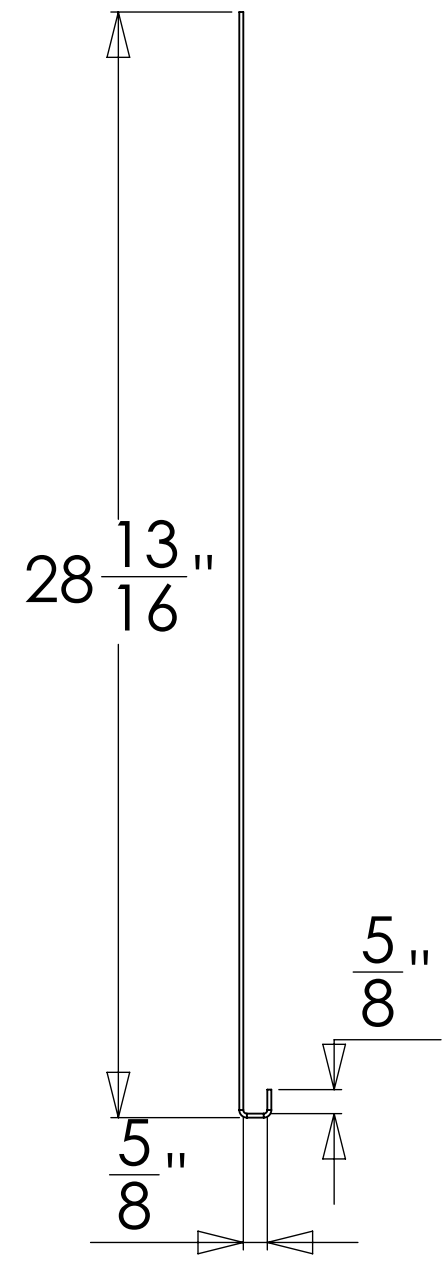

TOP PLATE

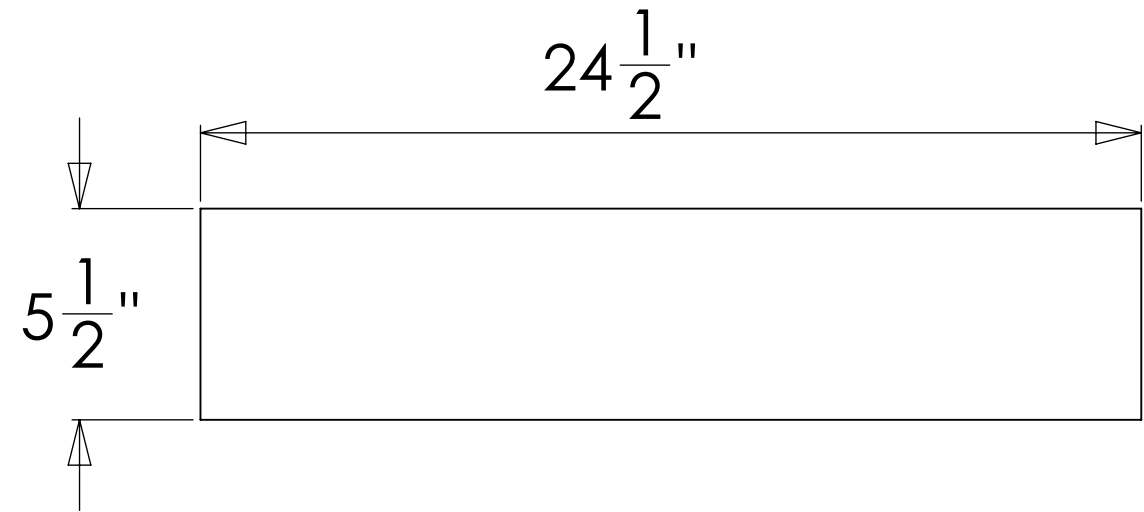

GUSSET

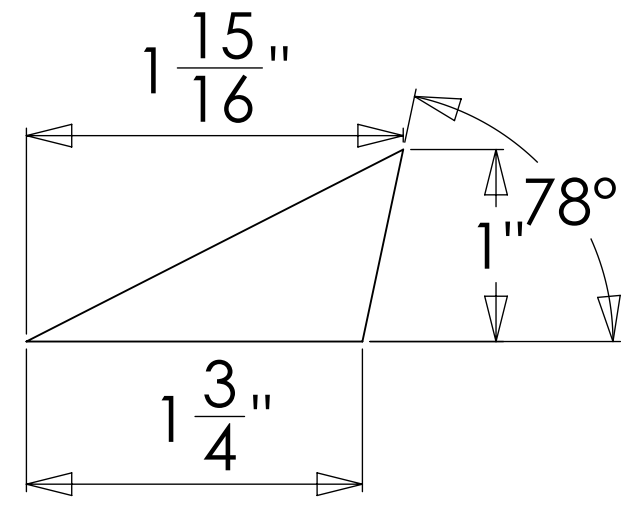

**PROPRIETARY AND CONFIDENTIAL**  
 THE INFORMATION CONTAINED IN THIS DRAWING IS THE SOLE PROPERTY OF National Horseshoe Pitcher's Association. ANY REPRODUCTION IN PART OR AS A WHOLE WITHOUT THE WRITTEN PERMISSION OF National Horseshoe Pitcher's Association IS PROHIBITED.

		UNLESS OTHERWISE SPECIFIED:		NAME	DATE	 NATIONAL HORSESHOE PITCHER'S ASSOCIATION
		DIMENSIONS ARE IN INCHES TOLERANCES: FRACTIONAL ± ANGULAR: MACH ± BEND ± TWO PLACE DECIMAL ± THREE PLACE DECIMAL ±		DRAWN	CAR	
		INTERPRET GEOMETRIC TOLERANCING PER:		CHECKED		TITLE: <h1>STAKE POST DETAILS</h1>
		MATERIAL SEE PART LIST		ENG APPR.		
		FINISH		MFG APPR.		
NEXT ASSY	USED ON			Q.A.		SIZE <b>B</b> DWG. NO. <b>SPAD</b> REV
APPLICATION		DO NOT SCALE DRAWING		COMMENTS:		SCALE: 1:5 WEIGHT: SHEET 2 OF 3

8 7 6 5 4 3 2 1

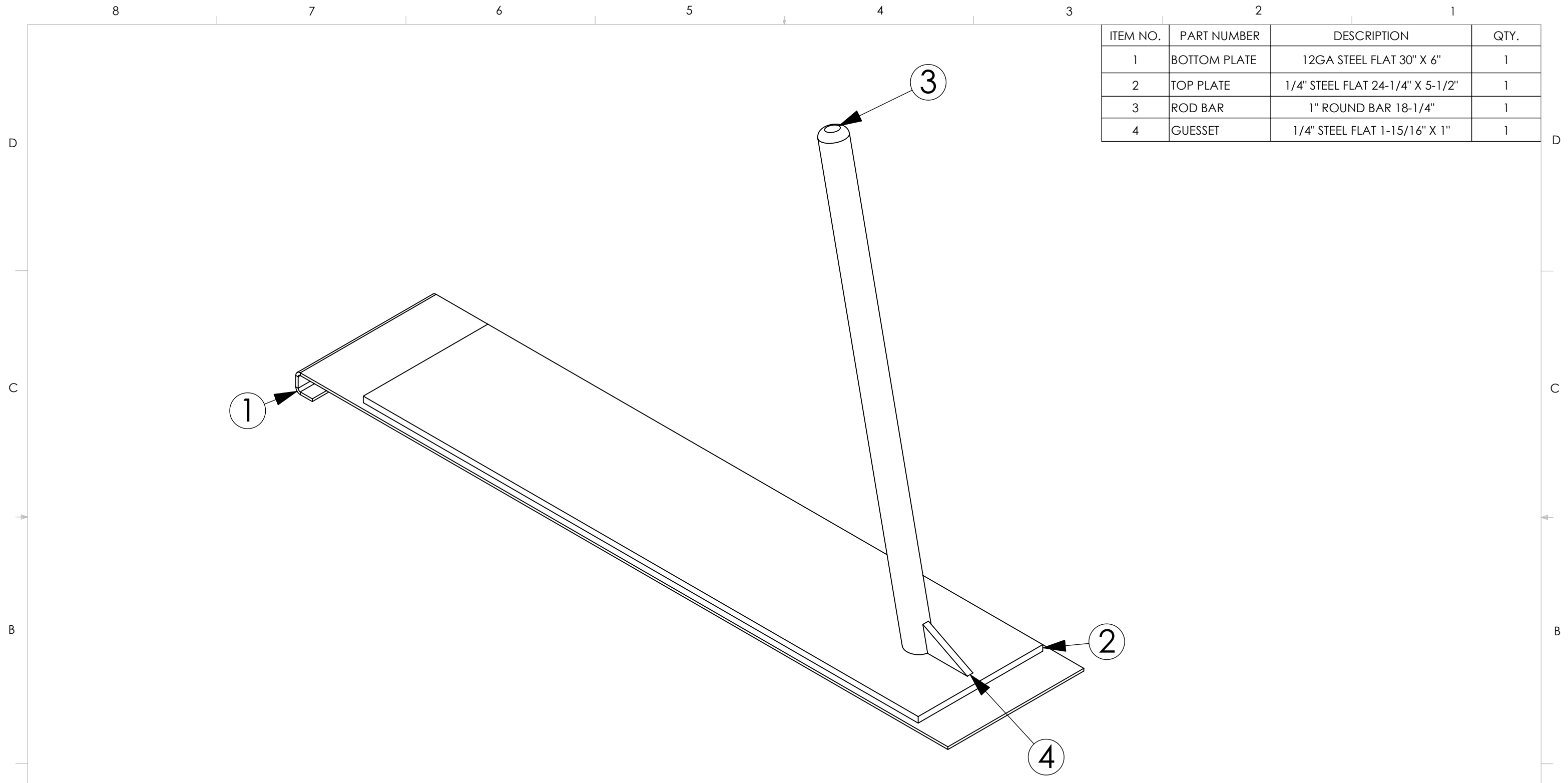

ITEM NO.	PART NUMBER	DESCRIPTION	QTY.
1	BOTTOM PLATE	12GA STEEL FLAT 30" X 6"	1
2	TOP PLATE	1/4" STEEL FLAT 24-1/4" X 5-1/2"	1
3	ROD BAR	1" ROUND BAR 18-1/4"	1
4	GUESSET	1/4" STEEL FLAT 1-15/16" X 1"	1

**PROPRIETARY AND CONFIDENTIAL**  
 THE INFORMATION CONTAINED IN THIS DRAWING IS THE SOLE PROPERTY OF National Horseshoe Pitcher's Association. ANY REPRODUCTION IN PART OR AS A WHOLE WITHOUT THE WRITTEN PERMISSION OF National Horseshoe Pitcher's Association IS PROHIBITED.

		UNLESS OTHERWISE SPECIFIED:				NAME		DATE		 NATIONAL HORSESHOE PITCHER'S ASSOCIATION	
		DIMENSIONS ARE IN INCHES		DRAWN		CAR		6/25/08		TITLE:	
		TOLERANCES:		CHECKED						<b>STAKE POST PART LIST</b>	
		FRACTIONAL ±		ENG APPR.						SIZE	
		ANGULAR: MACH ± BEND ±		MFG APPR.						<b>B</b>	
		TWO PLACE DECIMAL ±		Q.A.						DWG. NO.	
		THREE PLACE DECIMAL ±		COMMENTS:						<b>SPAP</b>	
		INTERPRET GEOMETRIC TOLERANCING PER:								REV	
		MATERIAL		NEXT ASSY		USED ON					
		SEE PART LIST									
		FINISH		APPLICATION						SCALE: 1:3	
										WEIGHT:	
		DO NOT SCALE DRAWING								SHEET 3 OF 3	