

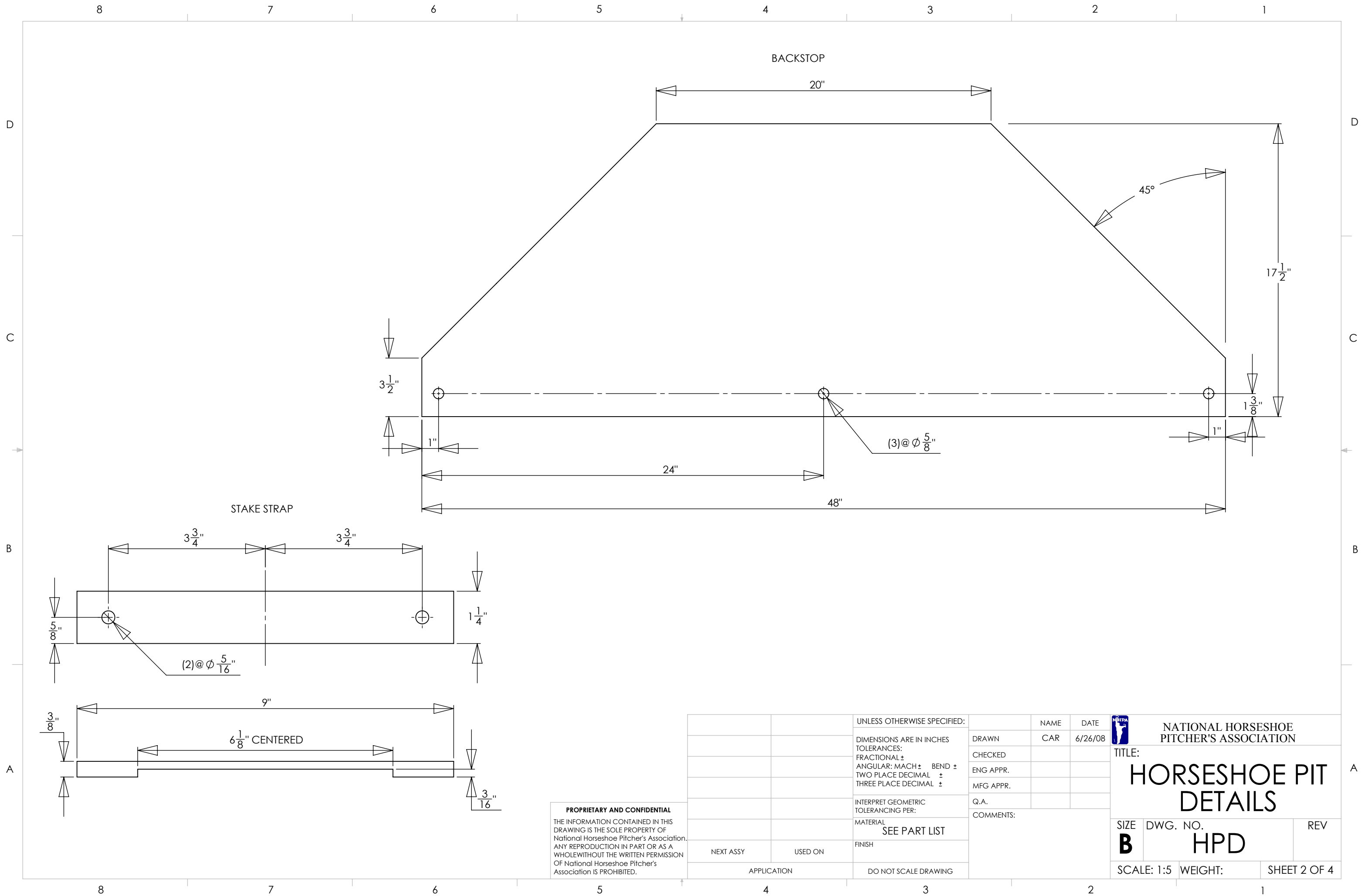

PROPRIETARY AND CONFIDENTIAL
 THE INFORMATION CONTAINED IN THIS DRAWING IS THE SOLE PROPERTY OF National Horseshoe Pitcher's Association. ANY REPRODUCTION IN PART OR AS A WHOLE WITHOUT THE WRITTEN PERMISSION OF National Horseshoe Pitcher's Association IS PROHIBITED.

		UNLESS OTHERWISE SPECIFIED:		NAME	DATE	 NATIONAL HORSESHOE PITCHER'S ASSOCIATION
		DIMENSIONS ARE IN INCHES TOLERANCES: FRACTIONAL ± ANGULAR: MACH ± BEND ± TWO PLACE DECIMAL ± THREE PLACE DECIMAL ±		DRAWN	CAR	
		INTERPRET GEOMETRIC TOLERANCING PER:		CHECKED		TITLE:
		MATERIAL SEE PART LIST		ENG APPR.		HORSESHOE PIT ASSEMBLY
		FINISH		MFG APPR.		
NEXT ASSY	USED ON			Q.A.		DWG. NO.
APPLICATION		DO NOT SCALE DRAWING		COMMENTS:		REV
						SCALE: 1:10
						WEIGHT:
						SHEET 1 OF 4



PROPRIETARY AND CONFIDENTIAL
 THE INFORMATION CONTAINED IN THIS DRAWING IS THE SOLE PROPERTY OF National Horseshoe Pitcher's Association. ANY REPRODUCTION IN PART OR AS A WHOLE WITHOUT THE WRITTEN PERMISSION OF National Horseshoe Pitcher's Association IS PROHIBITED.

		UNLESS OTHERWISE SPECIFIED:		NAME	DATE
		DIMENSIONS ARE IN INCHES	DRAWN	CAR	6/26/08
		TOLERANCES:	CHECKED		
		FRACTIONAL ±	ENG APPR.		
		ANGULAR: MACH ± BEND ±	MFG APPR.		
		TWO PLACE DECIMAL ±	Q.A.		
		THREE PLACE DECIMAL ±	COMMENTS:		
		INTERPRET GEOMETRIC TOLERANCING PER:			
		MATERIAL			
		SEE PART LIST			
		FINISH			
NEXT ASSY	USED ON				
APPLICATION		DO NOT SCALE DRAWING			

 NATIONAL HORSESHOE PITCHER'S ASSOCIATION		
TITLE: HORSESHOE PIT DETAILS		
SIZE	DWG. NO.	REV
B	HPD	
SCALE: 1:5	WEIGHT:	SHEET 2 OF 4

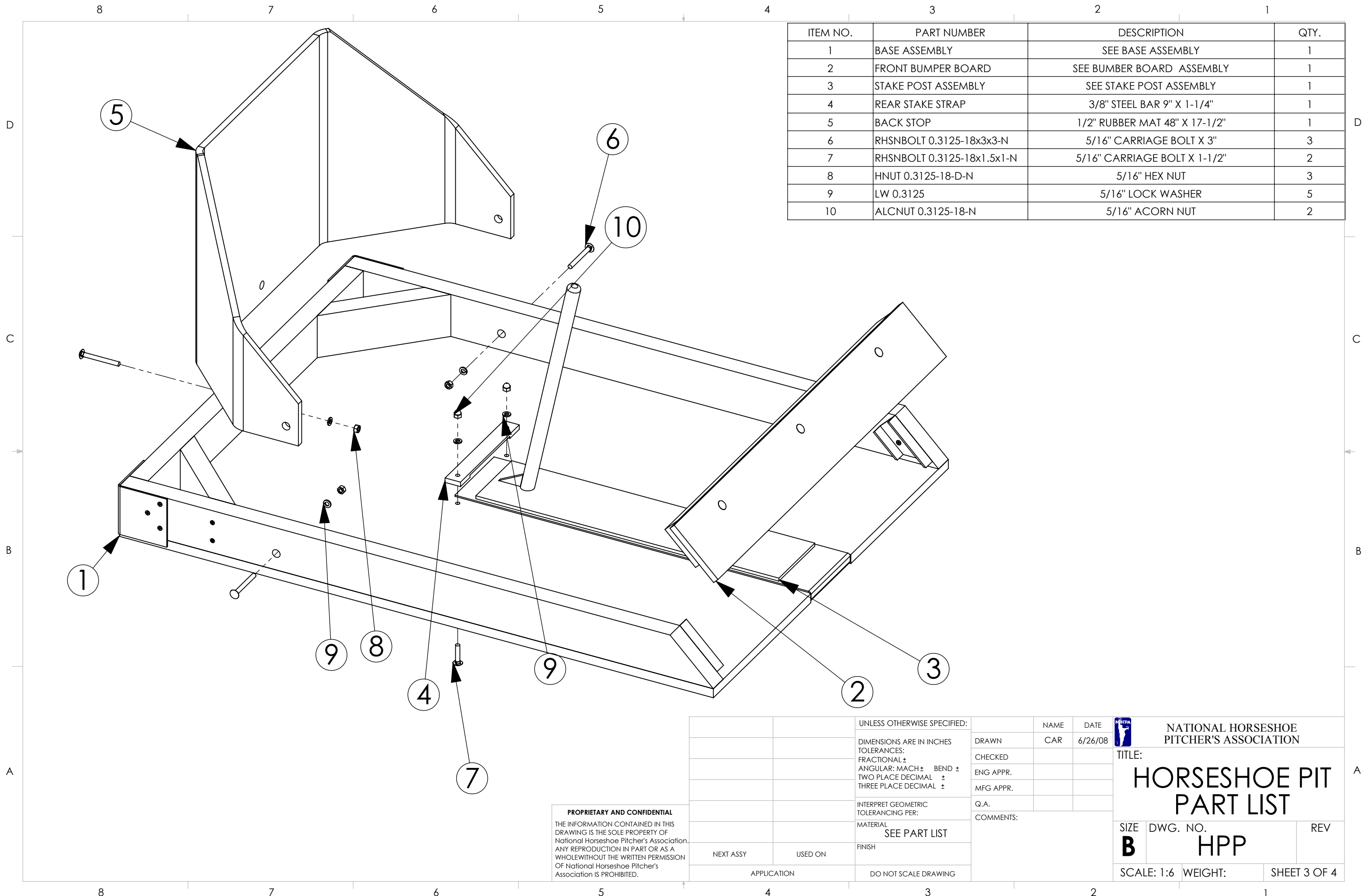

ITEM NO.	PART NUMBER	DESCRIPTION	QTY.
1	BASE ASSEMBLY	SEE BASE ASSEMBLY	1
2	FRONT BUMPER BOARD	SEE BUMPER BOARD ASSEMBLY	1
3	STAKE POST ASSEMBLY	SEE STAKE POST ASSEMBLY	1
4	REAR STAKE STRAP	3/8" STEEL BAR 9" X 1-1/4"	1
5	BACK STOP	1/2" RUBBER MAT 48" X 17-1/2"	1
6	RHSNBOLT 0.3125-18x3x3-N	5/16" CARRIAGE BOLT X 3"	3
7	RHSNBOLT 0.3125-18x1.5x1-N	5/16" CARRIAGE BOLT X 1-1/2"	2
8	HNUT 0.3125-18-D-N	5/16" HEX NUT	3
9	LW 0.3125	5/16" LOCK WASHER	5
10	ALCNUT 0.3125-18-N	5/16" ACORN NUT	2

PROPRIETARY AND CONFIDENTIAL
 THE INFORMATION CONTAINED IN THIS DRAWING IS THE SOLE PROPERTY OF National Horseshoe Pitcher's Association. ANY REPRODUCTION IN PART OR AS A WHOLE WITHOUT THE WRITTEN PERMISSION OF National Horseshoe Pitcher's Association IS PROHIBITED.

UNLESS OTHERWISE SPECIFIED:		NAME	DATE	 NATIONAL HORSESHOE PITCHER'S ASSOCIATION
DIMENSIONS ARE IN INCHES		DRAWN	CAR	
TOLERANCES:		CHECKED		TITLE:
FRACTIONAL ±		ENG APPR.		HORSESHOE PIT PART LIST
ANGULAR: MACH ± BEND ±		MFG APPR.		SIZE
TWO PLACE DECIMAL ±		Q.A.		B
THREE PLACE DECIMAL ±		COMMENTS:		DWG. NO.
INTERPRET GEOMETRIC TOLERANCING PER:				HPP
MATERIAL				REV
SEE PART LIST				
FINISH				
NEXT ASSY	USED ON			
APPLICATION	DO NOT SCALE DRAWING			
		SCALE: 1:6	WEIGHT:	SHEET 3 OF 4