

SECTION A-A

PROPRIETARY AND CONFIDENTIAL
 THE INFORMATION CONTAINED IN THIS DRAWING IS THE SOLE PROPERTY OF National Horseshoe Pitcher's Association. ANY REPRODUCTION IN PART OR AS A WHOLE WITHOUT THE WRITTEN PERMISSION OF National Horseshoe Pitcher's Association IS PROHIBITED.

		UNLESS OTHERWISE SPECIFIED:		NAME	DATE	 NATIONAL HORSESHOE PITCHER'S ASSOCIATION		
		DIMENSIONS ARE IN INCHES TOLERANCES: FRACTIONAL ± ANGULAR: MACH ± BEND ± TWO PLACE DECIMAL ± THREE PLACE DECIMAL ±		DRAWN	CAR		6/25/08	
		INTERPRET GEOMETRIC TOLERANCING PER:		CHECKED		TITLE:		
		MATERIAL SEE PART LIST		ENG APPR.		BASE ASSEMBLY		
		FINISH		MFG APPR.				
NEXT ASSY	USED ON			Q.A.		SIZE	DWG. NO.	REV
APPLICATION		DO NOT SCALE DRAWING		COMMENTS:		B	BA	
						SCALE: 1:8	WEIGHT:	SHEET 1 OF 4

8 7 6 5 4 3 2 1

D
C
B
A

D
C
B
A

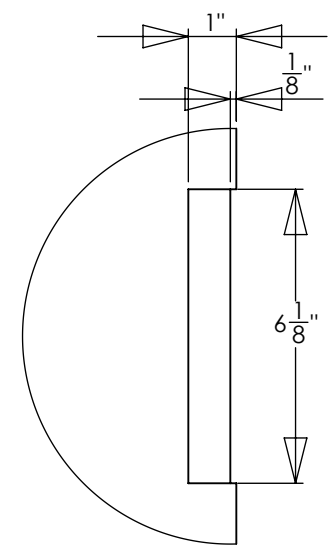
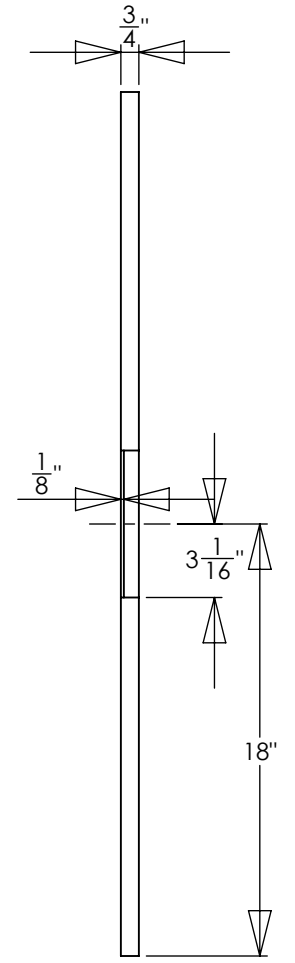
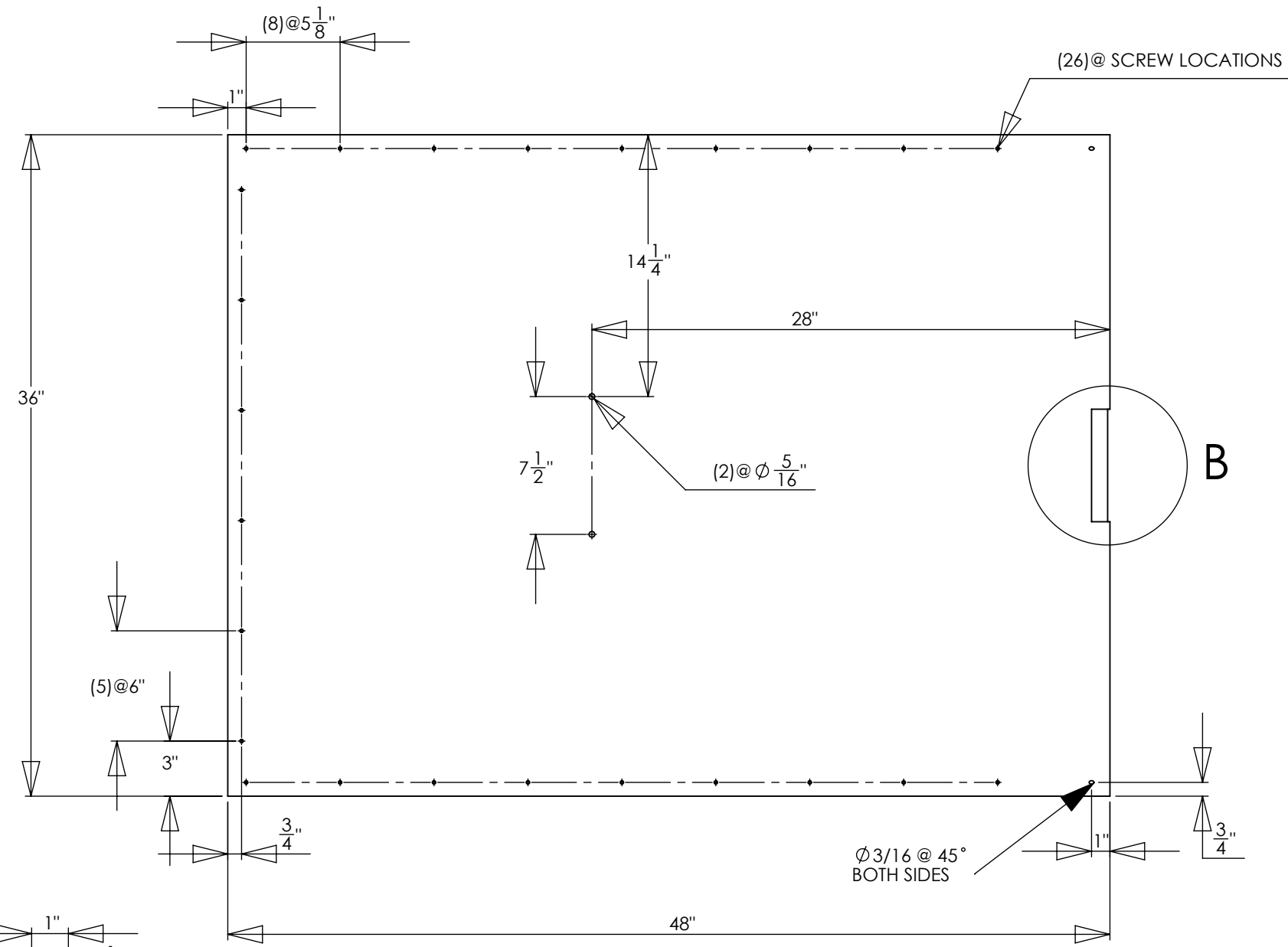

DETAIL B
SCALE 1 : 4

PROPRIETARY AND CONFIDENTIAL
THE INFORMATION CONTAINED IN THIS DRAWING IS THE SOLE PROPERTY OF National Horseshoe Pitcher's Association. ANY REPRODUCTION IN PART OR AS A WHOLE WITHOUT THE WRITTEN PERMISSION OF National Horseshoe Pitcher's Association IS PROHIBITED.

		UNLESS OTHERWISE SPECIFIED:		NAME		DATE		 NATIONAL HORSESHOE PITCHER'S ASSOCIATION	
		DIMENSIONS ARE IN INCHES		DRAWN		CAR		6/25/08	
		TOLERANCES:		CHECKED				TITLE:	
		FRACTIONAL ±		ENG APPR.				BASE ASSEMBLY	
		ANGULAR: MACH ± BEND ±		MFG APPR.				PLYWOOD	
		TWO PLACE DECIMAL ±		Q.A.				SIZE	
		THREE PLACE DECIMAL ±		COMMENTS:				B	
		INTERPRET GEOMETRIC TOLERANCING PER:						DWG. NO.	
		MATERIAL						BAPW	
		3/4 PLYWOOD						REV	
		FINISH							
NEXT ASSY		USED ON							
APPLICATION		DO NOT SCALE DRAWING						SCALE: 1:8	
								WEIGHT:	
								SHEET 2 OF 4	

8 7 6 5 4 3 2 1

D

C

B

A

D

C

B

A

SIDE BOARD
2" X 4" LUMBER

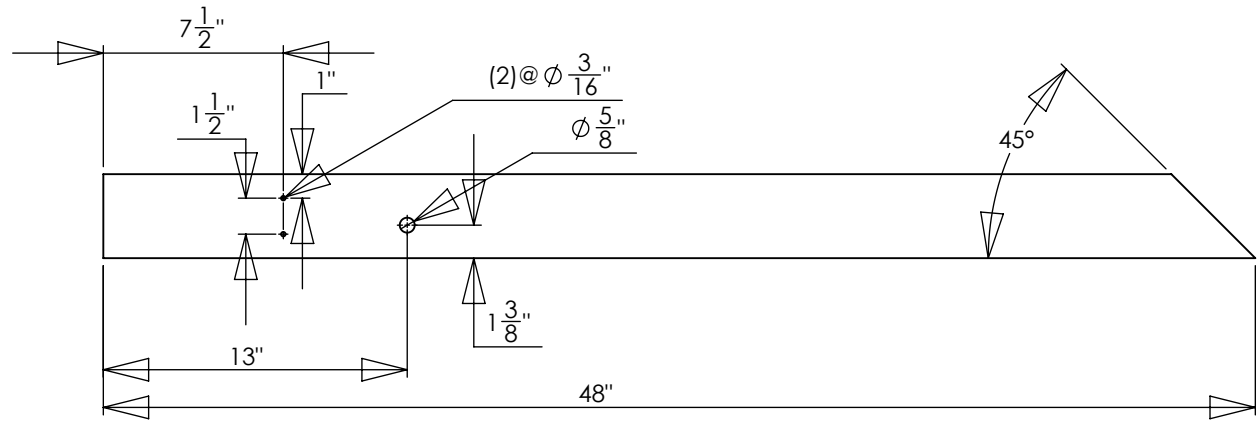

CORNER ANGLE FLAT

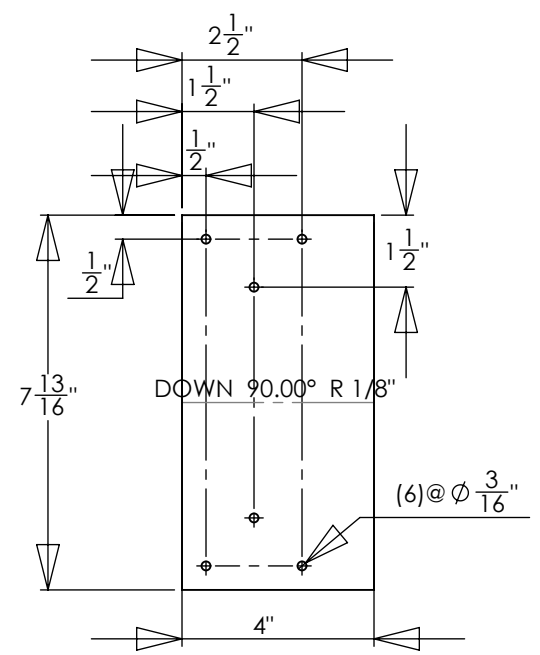

CORNER ANGLE

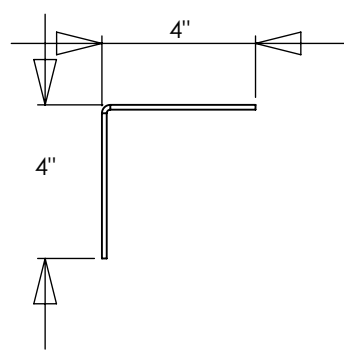

BACK BOARD
2" X 4" LUMBER

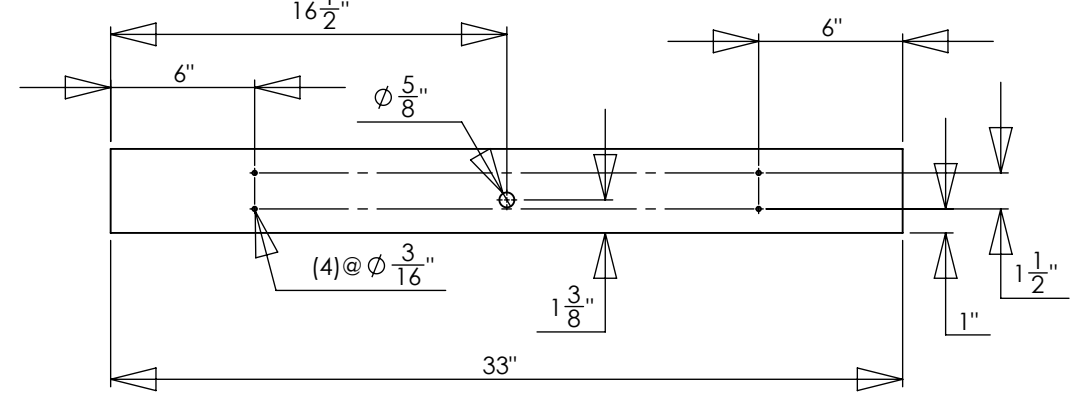

ALUMINUM CHANNEL

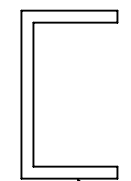
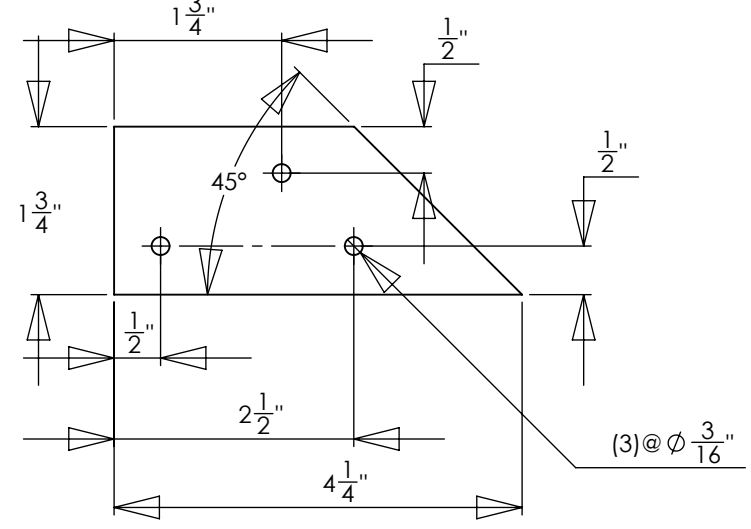

THERE IS A LEFT AND RIGHT VERSIONS OF THIS PART

PROPRIETARY AND CONFIDENTIAL
THE INFORMATION CONTAINED IN THIS DRAWING IS THE SOLE PROPERTY OF National Horseshoe Pitcher's Association. ANY REPRODUCTION IN PART OR AS A WHOLE WITHOUT THE WRITTEN PERMISSION OF National Horseshoe Pitcher's Association IS PROHIBITED.

		UNLESS OTHERWISE SPECIFIED:		NAME	DATE	 NATIONAL HORSESHOE PITCHER'S ASSOCIATION
		DIMENSIONS ARE IN INCHES TOLERANCES: FRACTIONAL ± ANGULAR: MACH ± BEND ± TWO PLACE DECIMAL ± THREE PLACE DECIMAL ±		DRAWN	CAR	
		INTERPRET GEOMETRIC TOLERANCING PER:		CHECKED		TITLE:
		MATERIAL SEE PART LIST		ENG APPR.		BASE ASSEMBLY DETAILS
		FINISH		MFG APPR.		
NEXT ASSY	USED ON			Q.A.		DWG. NO.
APPLICATION		DO NOT SCALE DRAWING		COMMENTS:		B
						BAD
						REV
						SCALE: 1:8
						WEIGHT:
						SHEET 3 OF 4

ITEM NO.	PART NUMBER	DESCRIPTION	QTY.
1	PLYWOOD BASE	3/4" PLYWOOD 48" X 36"	1
2	SIDE 2X4	2" X 4" LUMBER X 48" 45° ONE END	2
3	BACK BOARD	2" X 4" LUMBER X 33"	1
4	ALUM CHANNEL	ALUMINUM CHANNEL 1-3/4" X 1" X 1/8" X 4-1/4" 45° ONE END SEE SHEET 3	1
5	LEFT ALUM CHANNEL	ALUMINUM CHANNEL 1-3/4" X 1" X 1/8" X 4-1/4" 45° ONE END SEE SHEET 3	1
6	CR-FHMS 0.19-24x1.5x2.5-N	#10 COATED DECK SCREWS 2-1/2"	26
7	CR-FHMS 0.19-24x1.5x1.5-N	#10 COATED DECK SCREWS 1-1/2"	26
8	CONNER ANGLE	1/8" FLAT STEEL 7-13/16" X 4"	2
9	CONNER BOARD	2" X 4" LUMBER X 10" 45° ON BOTH ENDS	2

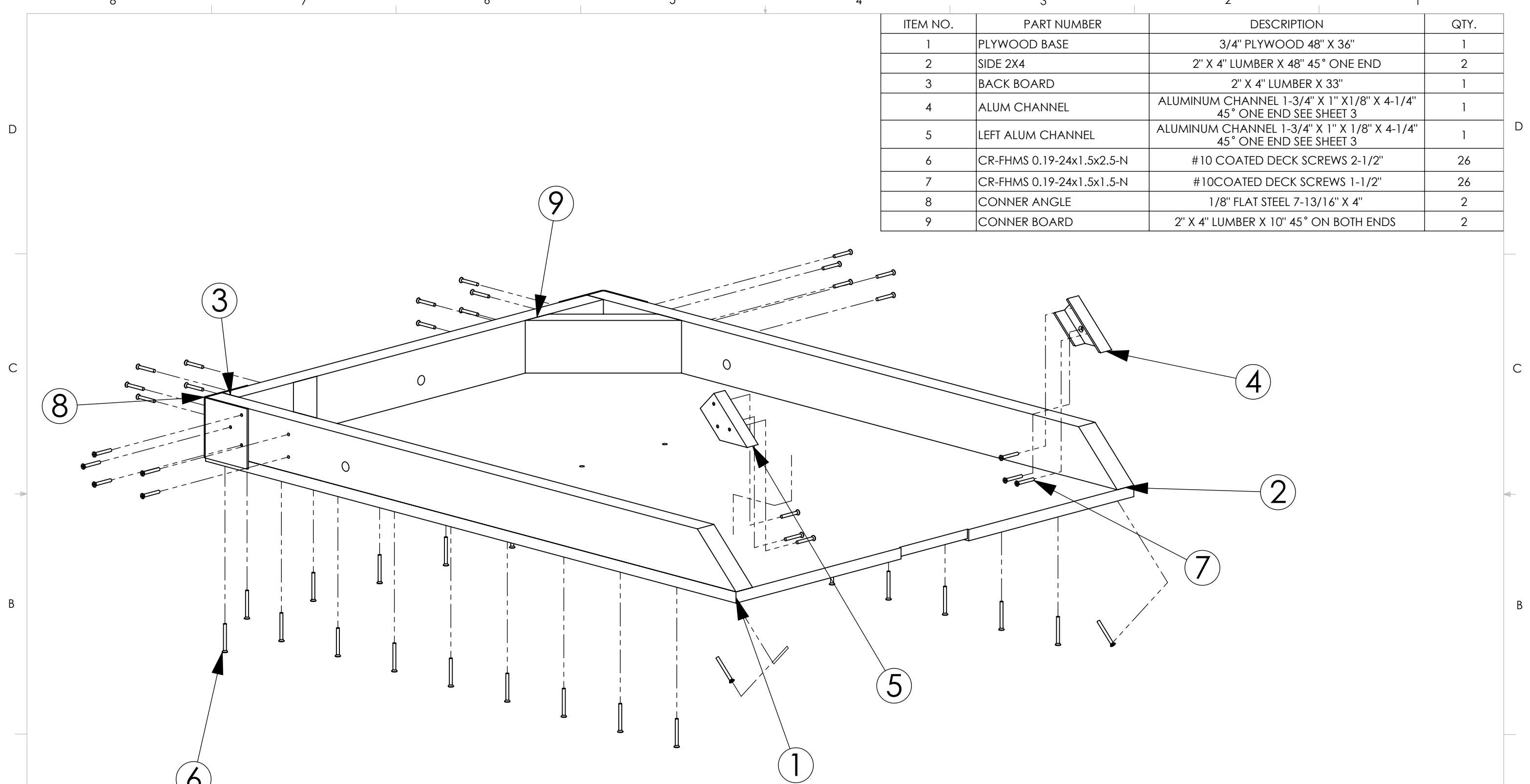

PROPRIETARY AND CONFIDENTIAL
 THE INFORMATION CONTAINED IN THIS DRAWING IS THE SOLE PROPERTY OF National Horseshoe Pitcher's Association. ANY REPRODUCTION IN PART OR AS A WHOLE WITHOUT THE WRITTEN PERMISSION OF National Horseshoe Pitcher's Association IS PROHIBITED.

UNLESS OTHERWISE SPECIFIED:		NAME	DATE	 NATIONAL HORSESHOE PITCHER'S ASSOCIATION
DIMENSIONS ARE IN INCHES TOLERANCES: FRACTIONAL ± ANGULAR: MACH ± BEND ± TWO PLACE DECIMAL ± THREE PLACE DECIMAL ±		DRAWN	CAR	
INTERPRET GEOMETRIC TOLERANCING PER:		CHECKED		TITLE:
MATERIAL SEE PART LIST		ENG APPR.		BASE ASSEMBLY PART LIST
FINISH		MFG APPR.		SIZE DWG. NO. REV
NEXT ASSY	USED ON	Q.A.		B BAP
APPLICATION		COMMENTS:		SCALE: 1:6 WEIGHT: SHEET 4 OF 4
DO NOT SCALE DRAWING				